

# MINI DIAPHRAGM VACUUM PUMP

## LABOPORT® N 96



### Technical features

- 100 % oil-free transfer – thereby pure transferring, evacuation and compression of gases
- Extremely low footprint
- PTFE-coated diaphragm is ideal for aggressive/ corrosive gases and vapors
- Integrated rotational speed control
- Environmentally friendly

### Technical data

Flow rate [m <sup>3</sup> /h] at atm. pressure	0.4
Flow rate [l/min] at atm. pressure	7
Ultimate vacuum [mbar abs.]	< 130
Operating pressure [bar]	2.5
Voltage pump [V]	24 DC
Protection class	IP40
Power P <sub>2</sub> [W]	19
Operating current pump [A]	≈ 0.9
Voltage power-supply unit [V]	100-240 AC
Frequencies power-supply unit [Hz]	50/60
Operating current power-supply unit [A]	~ 1.25

### MATERIALS

Pump head	PPS
Diaphragm	PTFE-coated
Valves	FKM

### OTHER DATA

Weight [kg]	1.3
Gas connections	NPT 1/8 – hose connector ID6, PP is part of the supply
Dimensions W x H x D [mm]	156 x 119 x 75
Permissible media and ambient temperature [°C]	+5 to +40

### ACCESSORIES

	ID
Column fixture	323484

### SPARE PARTS

	ID
Spare parts kit	322636
Power-supply unit kit	323457
Silencer and hose connector ID6, PP	323456

## Dimensions

N 96

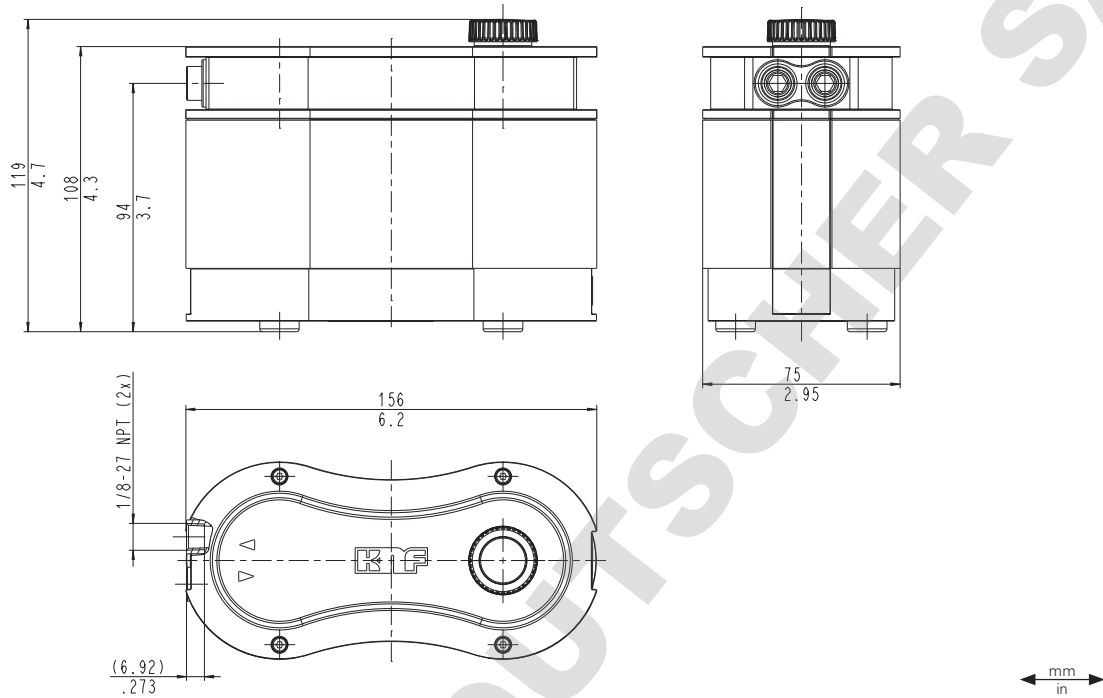

## Performance characteristics

### PUMP DOWN TIME FOR 5 LITER VESSEL

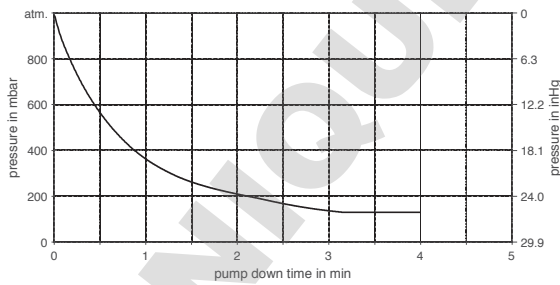

### FLOW RATE

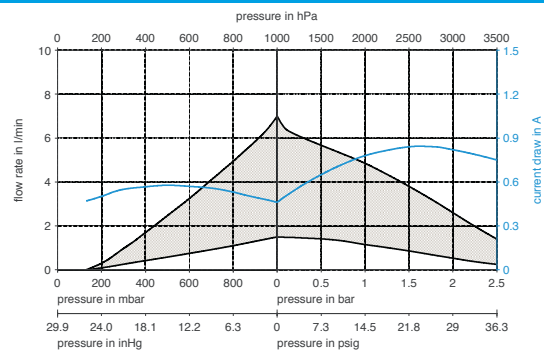

### SUCTION PUMPING SPEED AT MIN./MAX. MOTOR SPEED

