

Milli-Q®

Lab Water

Milli-Q® IQ 7000 purification system

An ultrapure water solution designed
with YOU in mind

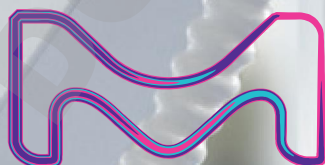

The life science business of Merck
operates as MilliporeSigma in the
U.S.A and Canada.

MERCK

A touch of intelligence

Milli-Q® IQ 7000 Purification System

Making your work in the lab easier
and more efficient than ever



Enjoy breakthrough design

Compact, ergonomic and intelligent. With its large touch screen for intuitive interaction, **the new Q-POD® ultrapure water dispenser** offers all the flexibility you need.

Discover how much you'll enjoy using it every day in your lab.

Simple and intuitive dispensing

Just a twist of the new dispensing wheel lets you deliver water at the flow rate you need, from precise drop by drop up to a full 2 liters per minute. For added efficiency, you can also directly select a dispensing option from the *Home* screen.

While dispensing, you can easily check the water quality parameters, always visible onscreen. Their values are continuously monitored by the system, so you can have full confidence in your water quality.



Feel free to continue working while the **Volumetric dispensing** mode fills labware for you. Water delivery will automatically stop when the programmed volume is reached.

To repeat this dispense as often as you like, simply push the button again.



Tip: Make sure to click the *Home* screen Recirculation button to refresh water quality just before dispensing.



Assisted dispensing

This new dispensing mode has a special drop-by-drop finish to always meet your calibration mark.

Designed for your precision filling needs, Assisted dispensing mode lets you avoid using an intermediary bottle or beaker — an extra step that is often a source of contamination.

Now you can directly use fresh ultrapure water without introducing unwanted contaminants into your samples.



The **Dispense report**, available right after water delivery, provides all dispense-related information in a single click.

Fill in the free text field to tag your project, your team, or even yourself to this dispense.

You can instantly export the report by scanning its QR code, or downloading it on a USB key.

The Dispense report data will be archived in Milli-Q® system memory for later retrieval.

Tip: Manage your Milli-Q expense sharing by tagging the user in the free text field.

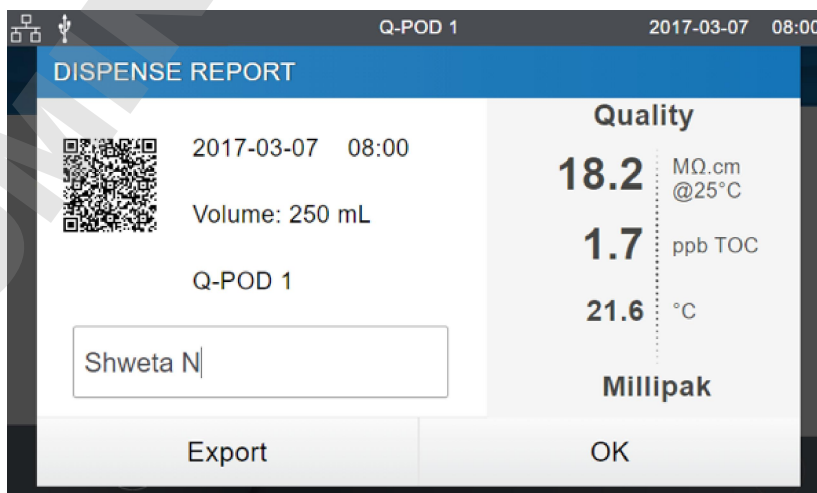

WORK CONFIDENTLY with Milli-Q® IQ 7000

Complementary technologies

The Milli-Q® IQ 7000 system combines advanced technologies, hydraulic design and software capabilities to efficiently produce the superior-quality ultrapure water you need to work confidently.

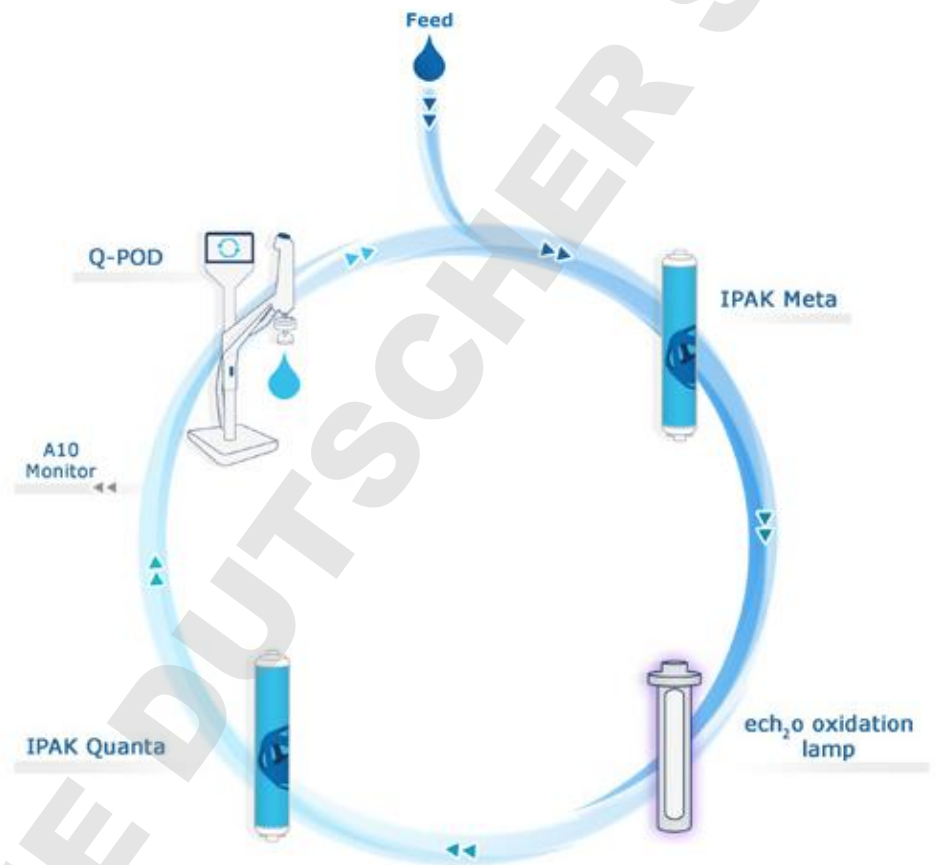

Boost your daily efficiency

The Q-POD® graphic interface is designed for intuitive use, just like a smartphone or a tablet. There's no need to search through the user manual — the information you need daily is at your fingertips.

And when consumables have to be replaced periodically, your system will inform you, then automatically guide you, step by step.

A powerful combination of purification media

The slim IPAK Meta® and IPAK Quanta® cartridges are designed to function as a pair. The cartridges use a combination of Jetpore® mixed-bed ion-exchange resin and innovative IQnano® ion-exchange media to provide exceptional performance.

The IQnano's smaller bead size significantly improves the resin's kinetic properties. This reduces media needs dramatically: 33% less than former Milli-Q® cartridges — while still achieving ion removal down to trace level.

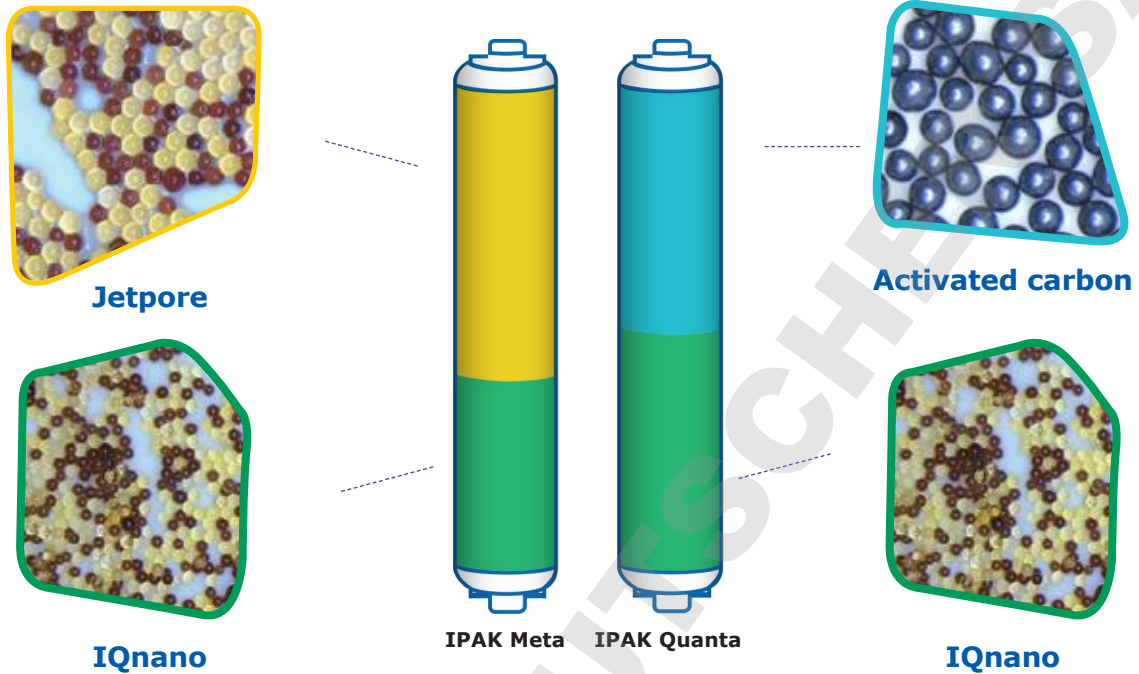

Completed by high-grade synthetic activated carbon, IPAK Quanta also targets traces of organic contaminants once they have been oxidized by the Milli-Q IQ 7000's new online photooxidation lamp. This unique $\text{ech}_2\text{o}^\circ$ mercury-free UV lamp ensures oxidation of organic contaminants using xenon excimer (excited dimer) technology, emitting at 172 nm wavelength.

And, because they contain no mercury, the new lamps are now environmentally friendly.



A Performance Report makes everything clear

A full report is available for the IPAK Meta and IPAK Quanta cartridges. It provides details on the technologies used, their performance during testing by our R&D department, as well as information concerning our quality and manufacturing requirements.

For more information, please visit www.mymilliqconsumables.com

see how superior quality is possible

Better than 18.2 MΩ·cm?

We have developed Milli-Q® IQ 7000 to ensure that your experiments are safe from ionic contaminant traces. Our R&D validation data in Ion Chromatography (IC) show that the system is able to consistently

and reliably produce 18.2 MΩ·cm (at 25°C) ion-free water at the sub-ppb level. This resistivity value is continuously monitored by the precise in-line resistivity cell, with a 0.01 cm⁻¹ low cell constant and a 0.1 °C sensitive thermistor.

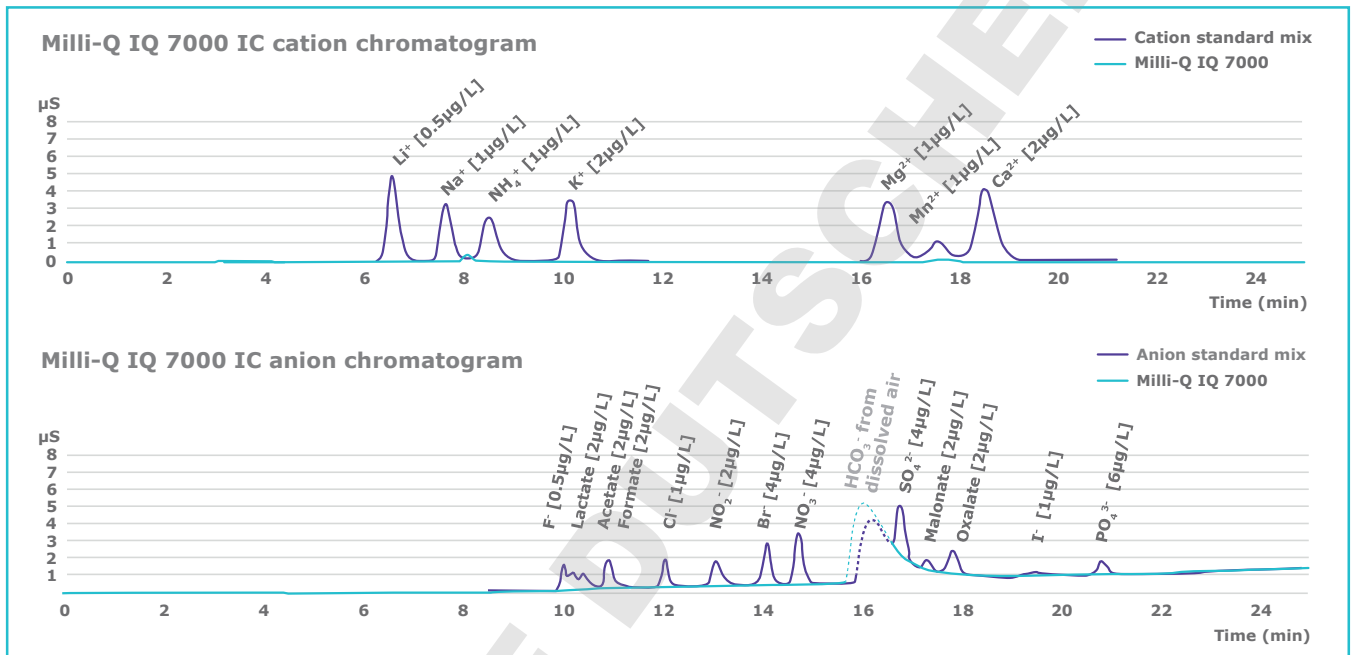

Milli-Q IQ 7000 also delivers low TOC (Total Organic Carbon) ultrapure water. Best results of less than 2 ppb are achieved with Elix® feed water. TOC is

measured online by the A10® monitor, which has been redesigned for even greater accuracy.

A10 TOC monitor benefits:

- ech₂o® mercury-free lamp
- High accuracy enabled by complete oxidation of organics to their end-point reaction, thanks to oxidation and conductivity measurements occurring within the same cell
- Range (0.5 – 999.9) and precision passing USP & EP suitability tests

TOC measuring process within the A10 quartz cell

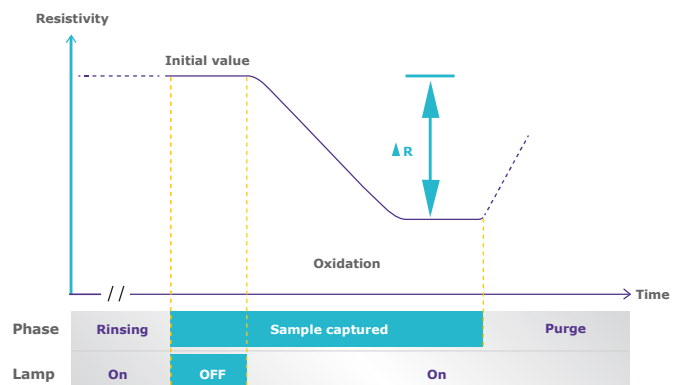

Elix® feed recommended

Feed your Milli-Q IQ 7000 system with pure Type 2 Elix water to get the best performance from your system and optimal cartridge lifetimes.

Water quality to match all your application needs

You'll find that our range of POD-Paks is the perfect solution for your various applications. Each of the Application-Pak polishers targets specific types of contaminants and removes them right at the Q-POD® dispenser.

Millipak® & sterile Millipak® Gold:
0.22 µm filters for bacteria-free and particulate-free water



EDS-Pak®: water for endocrine disruptor-related applications



Biopak®: pyrogen-, nuclease-, protease- and bacteria-free water



LC-Pak®: water for ultra trace organic sensitive applications



VOC-Pak®: water for volatile organic compounds related analyses

With the appropriate Application-Pak installed, your Milli-Q® IQ 7000 will provide water suitable for most of the analytical techniques used in the laboratory, including:

- HPLC • GC • LC-MS • AA • UPLC • CE
- MALDI-ToF-MS • Particle analysis • IC
- Surface tension • ICP • Spectrophotometry

In addition, specific Application-Paks are available for use with life sciences applications, such as:

- Cell culture • PCR • Western blotting • Sequencing
- Dissolution testing • Proteomics • Spectroscopy
- Genomics • Immunoassays • Microbiology

New application POD-Paks features:

- An e-Sure tag, for indispensable data traceability.
- An ergonomic pack locker and protective bell — for easy “snap-into-place” installation.

NOTE: Thanks to their e-Sure tag, all consumables' status can now be monitored on the Q-POD screen. Consumables' data and the events throughout their life are automatically recorded in the system's memory.

Tip: If you need several types of ultrapure water, simply connect up to 4 Q-POD dispensers to your system, each with a different POD-Pak.



optimize lab space for greater efficiency

Versatile configurations for the best fit

Each lab is unique. The Milli-Q® IQ 7000 system lets you optimize valuable lab space to help maximize your efficiency.

You may choose to wall-mount the production unit — or fit it under the bench. Designed for easy integration, the unit can be tucked into a corner, high up on a wall, or installed at a distance in a lab cabinet. Only the slim and neatly connected Q-POD® dispensers remain right at hand on the bench.

Cabling is available in customizable lengths and enclosed in protective sheathing for a neat, uncluttered installation.

Up to 4 Q-POD dispensers can be supplied by a single Milli-Q IQ 7000 production unit. This way, even scientists working at distant benches have convenient access to ultrapure water.

Tip: Take advantage of optional accessories, including a foot pedal for hands-free water delivery, or a water sensor that stops the system if a water leak is detected.



Get the data tracking you need

Easy data management for a paperless environment

Powerful, integrated data management makes it so much simpler and faster to manage your water system data — no more log book or paper to archive! All data generated by the Milli-Q® IQ 7000 is stored in the system memory.

With your needs in mind, we have tailor-made reports available in just a few clicks.

Dispensing Events is a history of all the dispensing reports. You can find a past dispense with its water quality, obtain how much volume you've used over a week, and even allocate costs using the User ID field.

Daily Quality Measures provides traceability on your water quality over time. Select your time frame to get a daily average of water quality parameters and volumes.

For all needs requiring more in-depth analysis, the **Complete History**, a global archive of ALL system data, is available. This includes not only water quality and volumes, but also any events such as alerts, setting modifications, consumables replacement, and other service activities.

Tip: All reports can be exported and are available in an open format suitable for any LIMS (laboratory information management system). The archiving function supports quality management systems, a growing industry trend.

A graphic preview is available with the last 30 events; conveniently export data on a flash drive using the screen's USB port.



Password protection

Critical Milli-Q IQ 7000 data can be protected by the use of a password. When active, the password limits access to certain key data, such as system set points or configuration parameters, to authorized users only.



Experience effortless Maintenance

Maintaining your Milli-Q® IQ 7000 system is worry-free and easier than ever! Your system has everything under control and will notify you whenever:

- Any consumables require replacement. You'll receive an alert and then your system will guide you step by step.
- A technical issue is encountered. Specific details will be provided for efficient troubleshooting.

note: In case of a serious issue, you are safe: your system will inform you and automatically stop!

The new IPAK locker makes changing system consumables so simple. Just twist and lock. Anyone can do it!



Tip: Need to order your consumables? Scan the QR code to be automatically connected to www.mymilliqconsumables.com

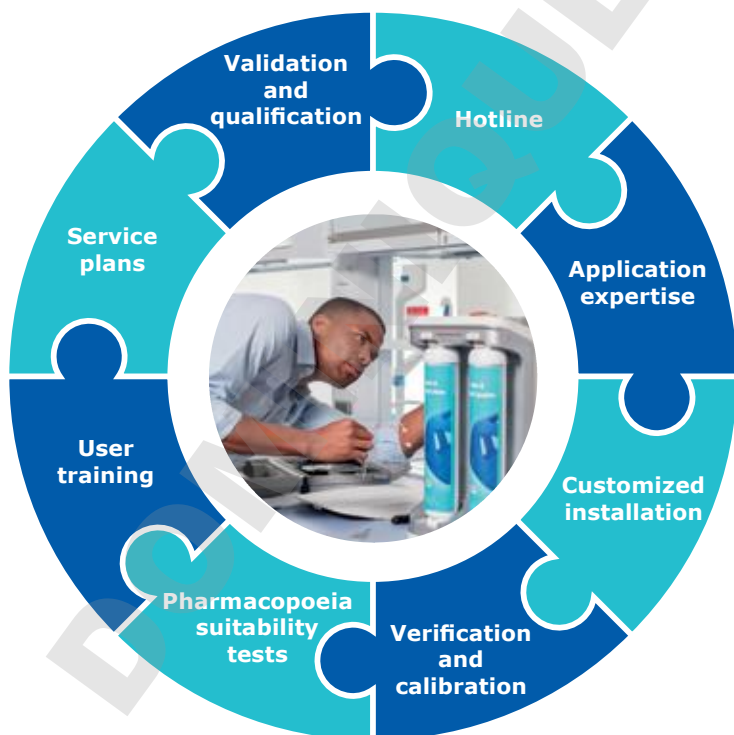

Focus 100% on your work with our comprehensive services

Thanks to the Watercare Pact, you can benefit from a range of services to help your system operate at optimum efficiency now – and in the future.

In all their activities, our certified service engineers follow strict standard procedures, use only genuine parts, and provide a formal service report in line with quality assurance guidelines.

Qualification expertise

Our full Qualification Program is designed to support laboratory validation procedures. The program includes qualification workbooks with IQ, OQ, MP (maintenance procedures) and examples of PQ files.

In addition, on-board resistivity meters and thermistors as well as the A10® TOC monitor, allow USP and EP suitability tests to be performed. Certificates of Conformity, Quality and Calibration are available to facilitate GLP and cGMP compliance.

Tip: Get instant online access to your certificates of quality at www.mymilliqconsumables.com

Compliance with Quality Assurance demands

Our products are manufactured in an ISO® 9001 and ISO® 14001-registered production site, and their certificates are available on demand. To assist you in following industry requirements, specific certification documents are also available:

Certificate of Conformity: The system has been assembled and tested to Merck's stringent Quality Assurance procedures.

Certificates of Calibration: Included for the built-in resistivity and temperature meters and the A10® TOC monitor.

Certificate of Quality: Included with all our consumables which have been validated to consistently deliver the water quality expected.

Performance Report: This document is available with information about cartridge development, validation and qualification stages, as well as manufacturing and quality assurance.

Water Quality Compliance

The Milli-Q® IQ 7000 system is intended to produce ultrapure water that meets or exceeds requirements as described by the organizations below:

Organization	Water quality / grade
European Pharmacopeia	Highly purified water
U.S. Pharmacopeia	Purified Water in bulk
Japanese Pharmacopeia	Purified Water
Chinese Pharmacopeia	Purified Water
ASTM® D1193	Type I water
ASTM® D5196	Bio-Application Grade Water (with appropriate final filter)
ISO® 3696	Grade 1 water
Chinese National Standard	GB 6682 Grade 1 water
JIS K 0557	A4 water
Clinical and Laboratory Standards Institute® (CLSI®)	Clinical Laboratory Reagent Water (CLRW)

The **Compliance Report** on Milli-Q IQ 7000 conformity to industry norms is also available upon request.

Be environmentally friendly

Merck is committed to environmental sustainability. Lab Water products are developed with the dual objective of increasing our own sustainability and helping our customers move toward sustainable solutions themselves.

Mercury-free solution

The Milli-Q IQ 7000 breaks new ground with the novel mercury-free technology of its ech₂o® UV lamps. And to do even more for the environment, we

also worked on reducing the system footprint (by 23%), and the cartridges (by 33%) — all of which reduce manufacturing plastic needs, packaging and transportation, as well as waste levels.

Finally, the system is designed to support a paperless environment, with documentation now available online. The system is delivered with its relevant certificates and a brief guide with hints and tips on system functions. The user manual can easily be downloaded from the Q-POD® screen.



Lab Close mode

The unique Lab Close mode effectively "hibernates" your system, preserving water quality with only minimum water and electricity usage when the lab must be closed for extended periods.

Technical Appendix

Milli-Q® IQ 7000 Purification System



Milli-Q® IQ 7000 Flow Schematic

Technical Appendix-1

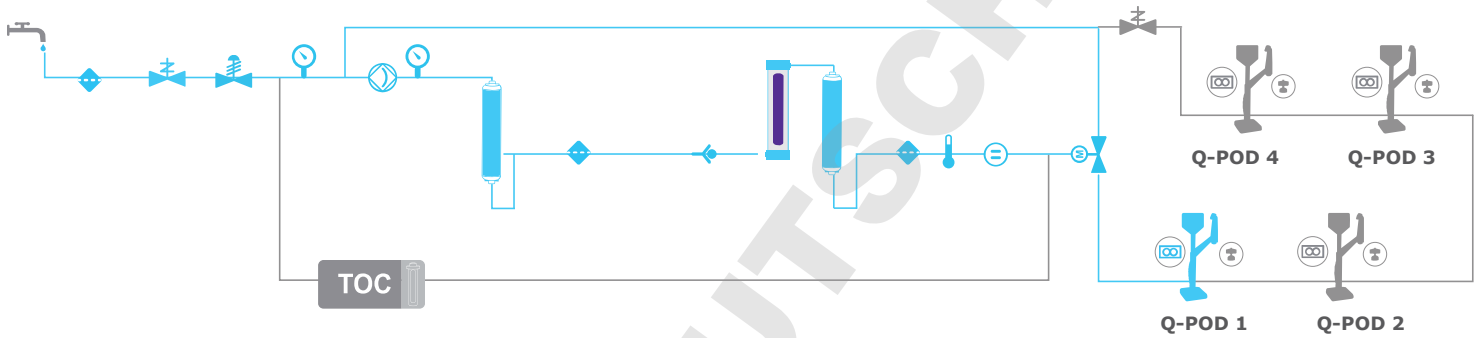

Feed water



Strainer



Pressure sensor



Check valve



Pump



Pressure regulator



Thermistor



Resistivity cell



Motorized valve



Flow meter



Solenoid valve



Q-POD dispenser



IPAK cartridge



A10 TOC monitor



ech₂o UV oxidation lamp

Production Unit Specifications

Technical Appendix-2

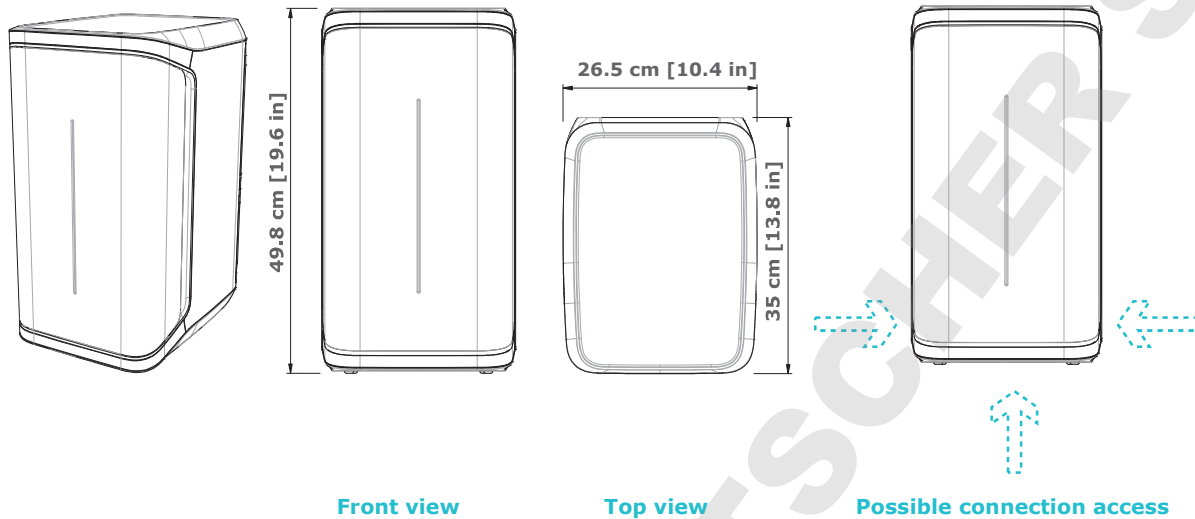

Tubing and port requirements

Item	Description
Feed water port	PE tube dia 6x8 mm, maximum 5 m (16.4 ft) from feed
Water to Q-POD® dispenser and back to production unit	PE tube dia 6x8 mm (inside connector sleeve), maximum length 5 m
Power entry	Connection IEC 13
ON/OFF switch	Available on the unit
Water sensor port	Maximum 3.3 VDC
Tank level adapter port	Maximum 5 VDC
Ethernet port	IEEE P802.3

Electrical connections and specifications

Item	Description
Power source voltage	100 – 240 V ± 10%
Power frequency	50 – 60 Hz at ± 2Hz
Power used	350 VA
Power cord	Length 2.5 m (8.2 ft) Plug: IEC13 female
Operational temperature	4 – 40 °C (39 – 104 °F)
Altitude	3000 m (9842 ft)
RFID frequency	13.56 MHz

Weight (Q-POD not included)

Shipping weight	Dry weight	Operating weight
15 kg (33 lb)	12.46 kg (27.47 lb)	16.06 kg (35.4 lb)

Q-POD® Dispenser Specifications

Technical Appendix-3

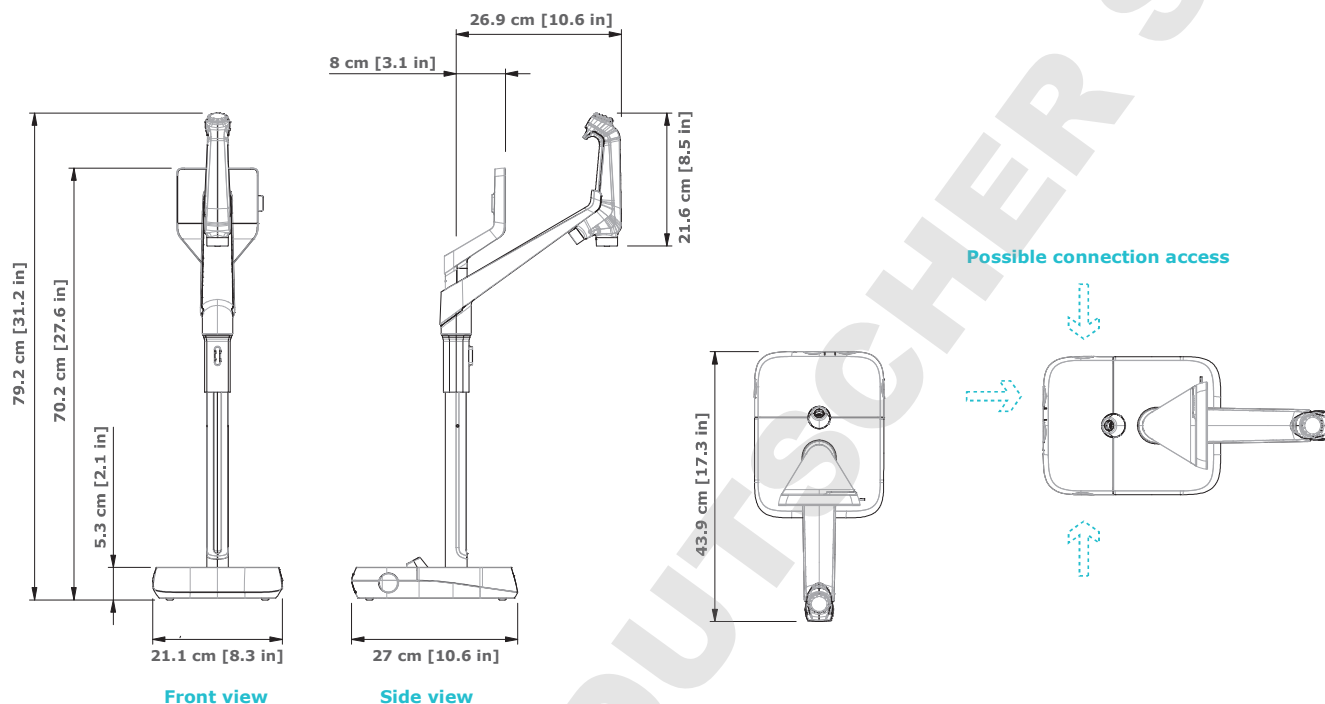

Tubeing and port requirements

Item	Description
Dispenser tubing length	0.92 m (36.22 in)
Distance from production unit to Q-POD® dispenser	Maximum 5 m (16.4 ft)
Distance between two Q-POD® dispensers (Maximum four Q-POD® dispensers connected in series)	Maximum 5 m (16.4 ft)
Q-POD® dispenser data connection with unit	Ethernet (cable inside connector sleeve)
Q-POD® electrical connection	Q-POD® is powered by the production unit (24 VDC - 28 VDC) (cable inside connector sleeve)
RFID frequency	13.56 MHz
Foot pedal port	3.3 V

Weight

Shipping weight	Dry weight	Operating weight
7.9 kg (17.4 lb)	5.5 kg (12.1 lb)	5.64 kg (12.4 lb)

Screen description & functionalities

Item	Description
Capacitive touch screen	Size: 5" Resolution: 800 x 480
USB port	USB 2.0 Highspeed standard
Speaker	Impedance: 8 Ω / Max output power: 0.5W
Display in 9 languages	Chinese / English / French / German / Italian / Japanese / Portuguese / Russian / Spanish

Installation Options To Fit Your Requirements

Technical Appendix-4

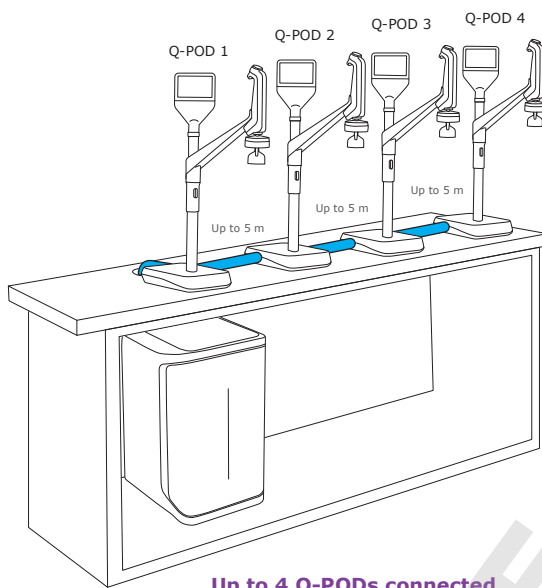

Up to 4 Q-PODs connected

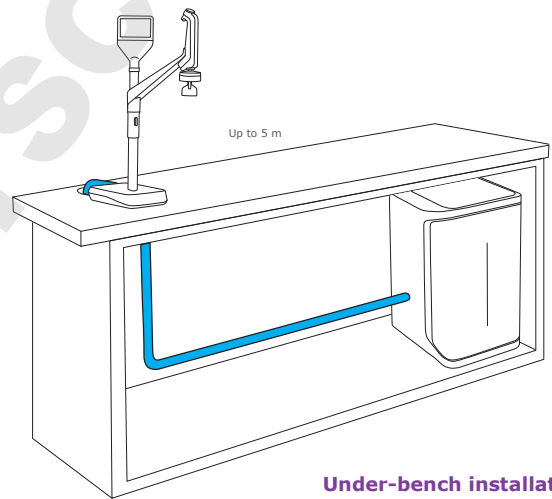

Under-bench installation

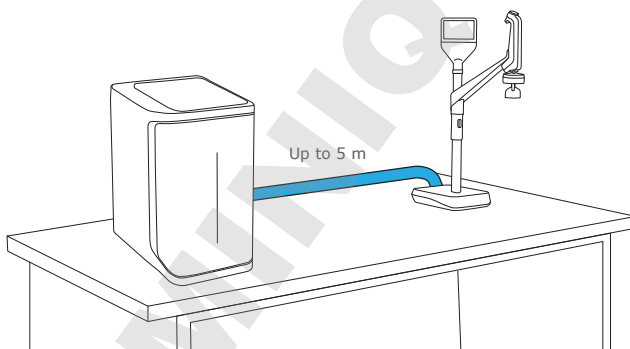

Bench-top installation

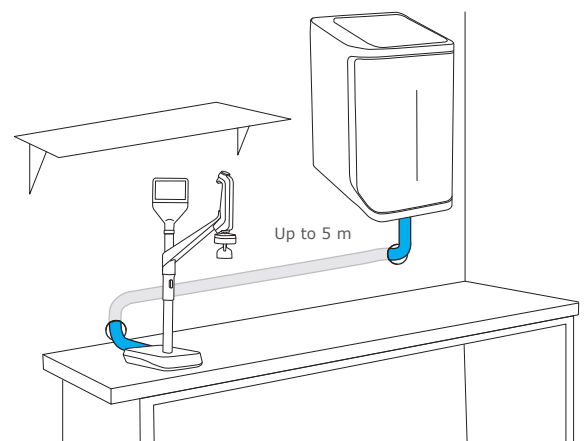

Wall-mounted installation

Water Specifications International Conformity

Technical Appendix-5

Feed water requirements

Feed water quality	Pretreated water using EDI, DI, RO or distillation technologies
Conductivity at 25 °C	<100 µS/cm
Total Organic Carbon (TOC)	<50 ppb
Pressure range*	Maximum 6 bar
Temperature	5 – 35 °C / 41 – 95 °F

* For pressures between 0 and 0.1 bar, the system will operate, but product flow rate may be lower.

Ultrapure, Type 1 water specifications⁽¹⁾ (from Q-POD dispenser)

Resistivity at 25 °C ⁽²⁾	18.2 MΩ·cm
TOC	≤2 ppb (µg/L) ⁽³⁾ , typically ≤ 5 ppb (µg/L)
Particles ⁽⁴⁾	No particles with size > 0.22 µm
Bacteria	<0.01 CFU/mL ^(4,5) <0.005 CFU/mL ⁽⁶⁾
Pyrogens (endotoxins) ⁽⁵⁾	<0.001 EU/mL
RNases ⁽⁵⁾	<1 pg/mL
DNases ⁽⁵⁾	<5 pg/mL
Proteases ⁽⁵⁾	<0.15 µg/mL
Flow rate	0.05 – 2 L/min

(1) These values are typical and may vary depending on the nature and concentration of contaminants in the feed water.

(2) Resistivity can also be displayed non-temperature-compensated as required by USP.

(3) In the appropriate operating conditions; otherwise typically ≤ 5 ppb.

(4) With Millipak® and Millipak® Gold.

(5) With Biopak®.

(6) With Millipak® Gold installed and used in a laminar flow hood.

International regulation requirements

Declaration of CE and cUL Conformity:

The Milli-Q® IQ 7000 system has been tested by an independent and accredited company for compliance with CE directives related to safety and

electromagnetic compatibility. The report can be consulted on demand. In addition, the Milli-Q IQ 7000 system is built using components and practices recommended by UL and has been cUL marked. The registration can be verified on the UL web site: www.ul.com

We also meet the regulatory requirements of the following organizations:



Ordering Information

Technical Appendix-6

Water purification system	Catalog number
Milli-Q® IQ 7000 purification system	ZIQ7000WW*
Q-POD® remote dispenser with 2 m connector	ZIQP0D020
Q-POD® remote dispenser with 5 m connector	ZIQP0D050

Purification cartridges	Catalog number
IPAK Meta® & IPAK Quanta® polishing cartridge kit	IPAKKITA1
Millipak® 0.22 µm filter	MPGP002A1
Millipak® Gold 0.22 µm sterile filter	MPGPG02A1
Biopak® polisher	CDUFBI0A1
LC-Pak® polisher	LCPAK00A1
EDS-Pak® polisher	EDSPAK0A1
VOC-Pak® polisher	V0CPAK0A1

Accessories	Catalog number
Additional Q-POD® dispenser with 2 m connector	ZIQP0DX20
Additional Q-POD® dispenser with 5 m connector	ZIQP0DX50
Feed water conductivity cell	ZFC0NDCA1
Foot pedal	ZMQSFTSA1
Wall mounting bracket	SYSTFIXA1
Water sensor	ZWATSENA1

Services

Our certified Field Service Engineers provide expert on-site professional support for the installation, validation, calibration and maintenance of your individual and total water solutions. To select the proper service plan for your water system, please contact your local service specialist to discuss and help you design the plan best adapted to your needs.

* The end letters "WW" will be replaced by your country letters on your invoice to ensure you receive the appropriate accessory kit for your country, including the user manual in your local language and a power cord adapted to the local electrical network.



To order consumables online, please visit:
www.mymilliqconsumables.com

For more information, please visit our website:
www.merckmillipore.com/milliq-iqsystem



For more information, please visit our website:
www.merckmillipore.com/labwater

Merck, MilliporeSigma, the vibrant M, Millipore, Milli-Q, Q-POD, Elix, Jetpore, ech₂o, IPAK Meta, IPAK Quanta, IQnano, VOC-Pak, Millipak, Biopak, EDS-Pak, LC-Pak, and A10 are trademarks of Merck KGaA.

ISO is a registered trademark of the International Organization for Standardization.

Clinical and Laboratory Standards Institute and CLSI are registered trademarks of the Clinical and Laboratory Standards Institute, Inc.

ASTM is a registered trademark of the American Society for Testing and Materials.

All other trademarks are the property of their respective owners.

Lit. No. PB5475ENEU

© 2017 EMD Millipore Corporation, Billerica, MA, U.S.A. All rights reserved.