

# Deep Well Plates 0.5 ml

Order number 96.09851.9.01 PP (CleanRoom Pure<sup>®</sup>); 96.09965.9.01 PP (γ sterilized)

## General Quality Characteristics

**Treff provides best Swiss made quality Deep Well Plates for general sample preparation purposes and storage applications.** Round bottom wells, alphanumeric grid, ANSI SLAS 2004 footprint for robotic handling, fit for magnetic separation devices and excellent physical and microbiological properties provide superb application results.

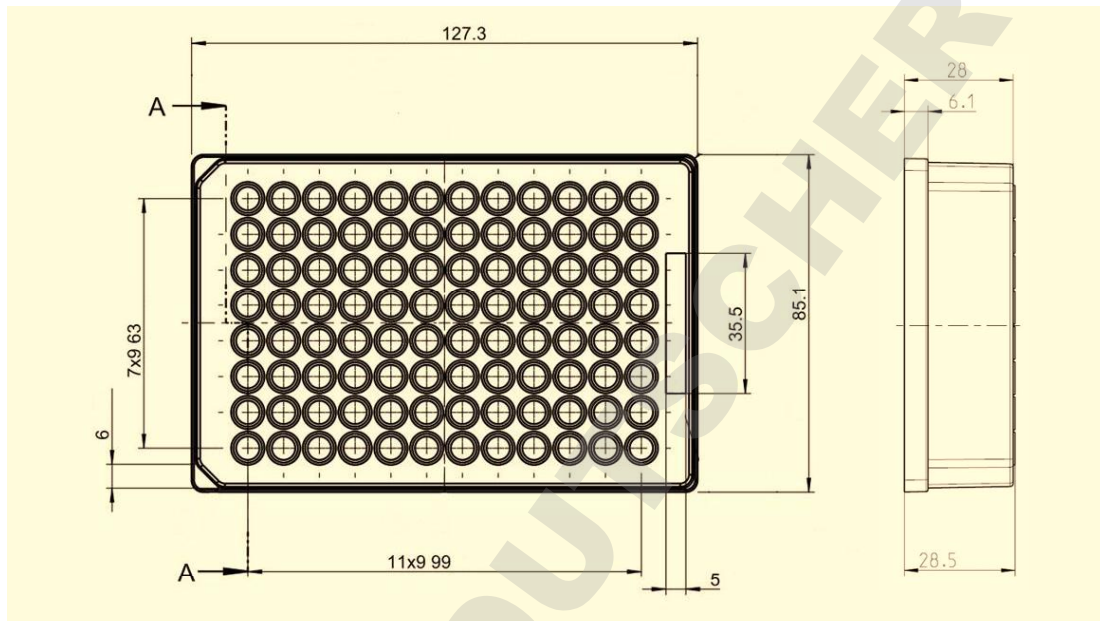

## Major Quality Characteristics

- 100% Virgin Polymer only, clean room class 8 production
- Free of DNase/RNase, human DNA, PCR inhibitors, endotoxins, ATP
- Strong physical properties
- 100% fully automated leak-tightness controlled
- Permanent flatness and wall thickness control
- Ready to Use: CleanRoom Pure<sup>®</sup>
- ANSI/ SLAS 2004 Standards
- Bottom shape: round (U)

## Physical Properties

Temperature Range: TreffLab Deep Well Plates withstand temperature range from PP: -80°C to autoclaving (121°C, 20 minutes, 100% humidity) according DIN EN 285

### Centrifuge forces:

*TreffLab 0.5 ml, 1.2 ml and 2.2 ml Deep Well Plates, PP or PS, have been developed to serve as «Sample preparation, assay and storage vessel» primarily. All Nolato Treff DWP are suitable for centrifugal applications with the following limits:*

*A) Using TreffLab Centrifugal Mat TreffLab Deep Well Plates withstand centrifugal g forces up to 6'000 RCF.*

*B) When no TreffLab<sup>®</sup> Centrifugal Mat is used, Nolato Treff AG do not to surpassed a centrifugal g force > 2000 RCF*

*However, Nolato Treff will not guarantee any centrifugal stability as since compliance with critical physical parameters are mandatory. In order to achieve such stability, i.e. proper counterbalance (> 0.1 gram), appropriate centrifugal swing plates, proper DWP positioning at swing plate, stress reduction of plate bottom by use of flexible support mat between DWP and swing plate is required. The homogeneity of DWP vial filling (ml) and the total sample weight per vial (g) within the 96 plate is also important, as well as a correct centrifugal operation.*

Overall this is technical information only. Please note that Treff cannot give any guarantee for centrifuge applications of its Deep Well Plates for the above mentioned reasons.

# Deep Well Plates 1.2 ml

Order number 96.08996.9.01 PP (CleanRoom Pure<sup>®</sup>); 96.09118.9.01 PP (γ sterilized)  
 Order number 96.08564.9.01 PS (CleanRoom Pure<sup>®</sup>); 96.08882.9.01 PS (γ sterilized)

## General Quality Characteristics

Treff provides best Swiss made quality Deep Well Plates for general sample preparation purposes and storage applications. Round bottom wells, alphanumeric grid, ANSI SLAS 2004 footprint for robotic handling, fit for magnetic separation devices and excellent physical and microbiological properties provide superb application results.

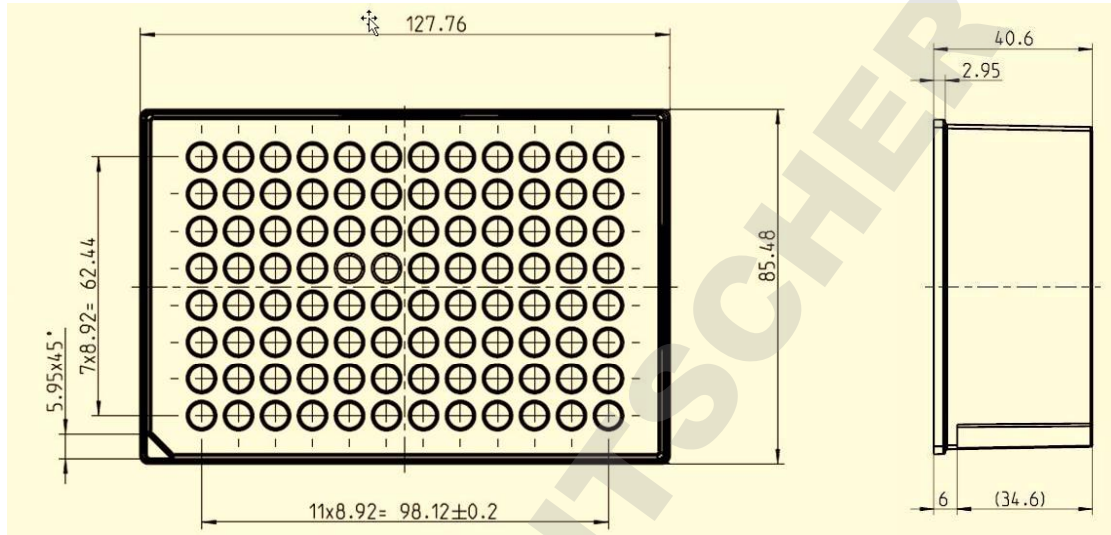

## Major Quality Characteristics

- 100% Virgin Polymer only, clean room class 8 production
- Free of DNase/RNase, human DNA, PCR inhibitors, endotoxins, ATP
- Strong physical properties
- 100% fully automated leak-tightness controlled
- Permanent flatness and wall thickness control
- Ready to Use: CleanRoom Pure<sup>®</sup>
- ANSI/ SLAS 2004 Standards
- Bottom shape: round (U)

## Physical Properties

Temperature Range: TreffLab Deep Well Plates withstand temperature range from  
 PP: -80°C to autoclaving (121°C, 20 minutes, 100% humidity) according DIN EN 285  
 PS: -20°C to 60°C

### Centrifuge forces:

TreffLab 0.5 ml, 1.2 ml and 2.2 ml Deep Well Plates, PP or PS, have been developed to serve as «Sample preparation, assay and storage vessel» primarily. All Nolato Treff DWP are suitable for centrifugal applications with the following limits:

A) Using TreffLab Centrifugal Mat TreffLab Deep Well Plates withstand centrifugal g forces up to 6'000 RCF.

B) When no TreffLab<sup>®</sup> Centrifugal Mat is used, Nolato Treff AG do not to surpassed a centrifugal g force > 2000 RCF

However, Nolato Treff will not guarantee any centrifugal stability as since compliance with critical physical parameters are mandatory. In order to achieve such stability, i.e. proper counterbalance (> 0.1 gram), appropriate centrifugal swing plates, proper DWP positioning at swing plate, stress reduction of plate bottom by use of flexible support mat between DWP and swing plate is required. The homogeneity of DWP vial filling (ml) and the total sample weight per vial (g) within the 96 plate is also important, as well as a correct centrifugal operation.

Overall this is technical information only. Please note that Treff cannot give any guarantee for centrifuge applications of its Deep Well Plates for the above mentioned reasons.

# Deep Well Plates 1.2 ml Rim

Order number 96.10842.9.01 PP (CleanRoom Pure<sup>®</sup>); 96.10852.9.01 PP (γ sterilized)

Order number 96.10841.9.01 PS (CleanRoom Pure<sup>®</sup>); 96.10851.9.01 PS (γ sterilized)

## General Quality Characteristics

**Treff provides best Swiss made quality Deep Well Plates for general sample preparation purposes and storage applications.** Raised rim for cross contamination protection and extra tight foil sealing. Round bottom wells, alphanumeric grid, fit for magnetic separation devices and excellent physical and microbiological properties provide superb application results.

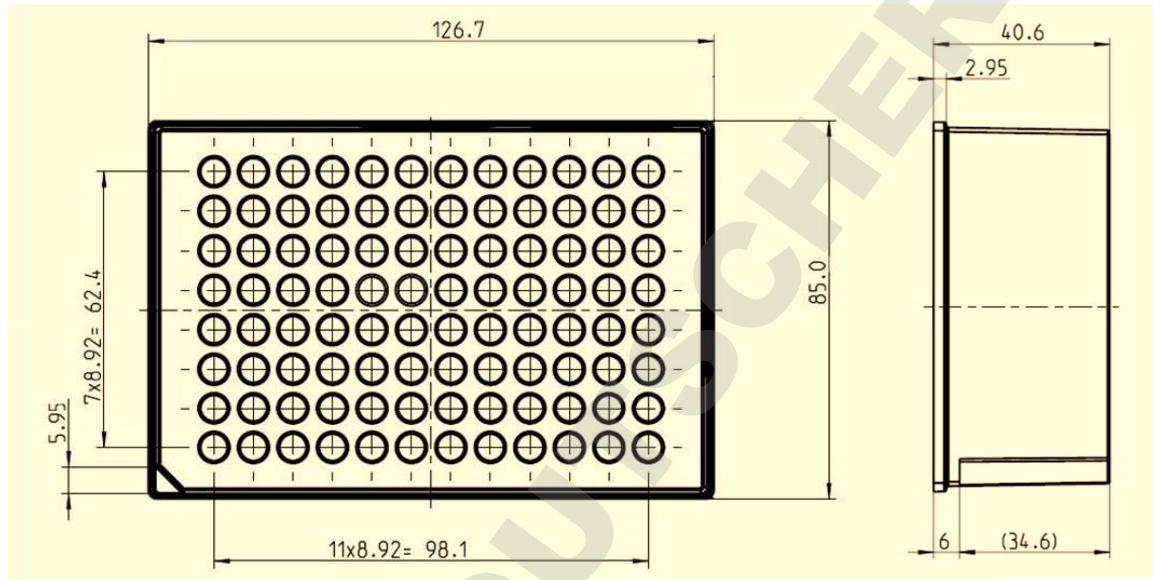

## Major Quality Characteristics

- 100% Virgin Polymer only, clean room class 8 production
- Free of DNase/RNase, human DNA, PCR inhibitors, endotoxins, ATP
- Strong physical properties
- 100% fully automated leak-tightness controlled
- Permanent flatness and wall thickness control
- Ready to Use: CleanRoom Pure<sup>®</sup>
- ANSI/ SLAS 2004 Standards
- Bottom shape: round (U)

## Physical Properties

Temperature Range: TreffLab Deep Well Plates withstand temperature range from  
 PP: -80°C to autoclaving (121°C, 20 minutes, 100% humidity) according DIN EN 285  
 PS: -20°C to 60°C

### Centrifuge forces:

*TreffLab 0.5 ml, 1.2 ml and 2.2 ml Deep Well Plates, PP or PS, have been developed to serve as «Sample preparation, assay and storage vessel» primarily. All Nolato Treff DWP are suitable for centrifugal applications with the following limits:*

*A) Using TreffLab Centrifugal Mat TreffLab Deep Well Plates withstand centrifugal g forces up to 6'000 RCF.*

*B) When no TreffLab<sup>®</sup> Centrifugal Mat is used, Nolato Treff AG do not to surpassed a centrifugal g force > 2000 RCF*

*However, Nolato Treff will not guarantee any centrifugal stability as since compliance with critical physical parameters are mandatory. In order to achieve such stability, i.e. proper counterbalance (> 0.1 gram), appropriate centrifugal swing plates, proper DWP positioning at swing plate, stress reduction of plate bottom by use of flexible support mat between DWP and swing plate is required. The homogeneity of DWP vial filling (ml) and the total sample weight per vial (g) within the 96 plate is also important, as well as a correct centrifugal operation.*

Overall this is technical information only. Please note that Treff cannot give any guarantee for centrifuge applications of its Deep Well Plates for the above mentioned reasons.

# Deep Well Plates 2.2 ml

Order number 96.09799.9.01 PP (CleanRoom Pure<sup>®</sup>); 96.09971.9.01 PP (γ sterilized)

## General Quality Characteristics

**Treff provides best Swiss made quality Deep Well Plates for general sample preparation purposes and storage applications.** Round bottom wells, alphanumeric grid, ANSI SLAS 2004 footprint for robotic handling, fit for magnetic separation devices and excellent physical and microbiological properties provide superb application results.

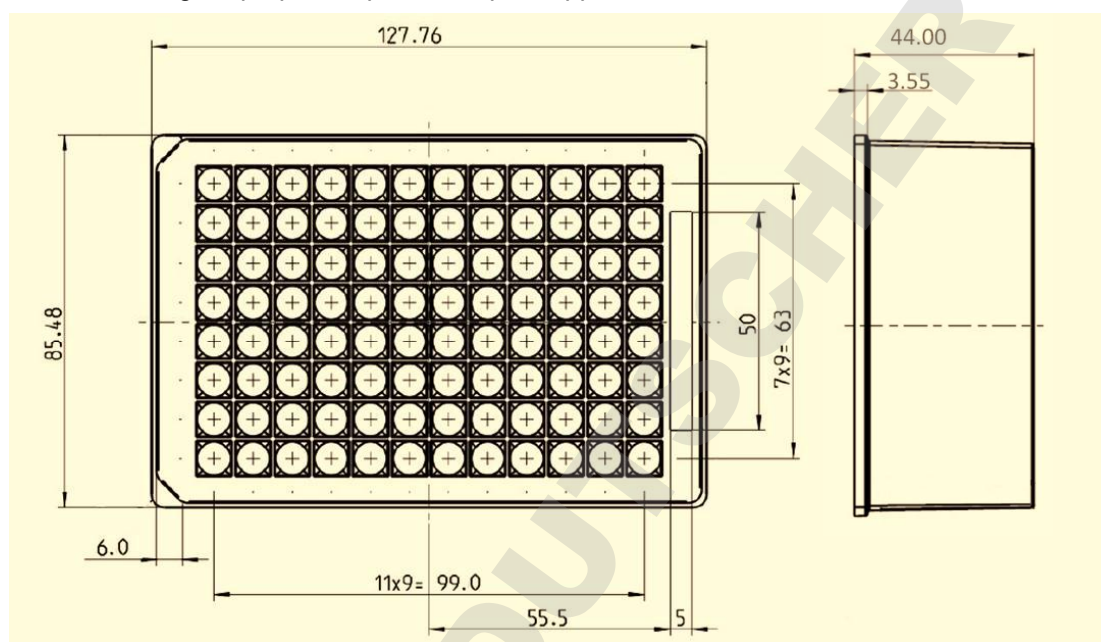

## Major Quality Characteristics

- 100% Virgin Polymer only, clean room class 8 production
- Free of DNase/RNase, human DNA, PCR inhibitors, endotoxins, ATP
- Strong physical properties
- 100% fully automated leak-tightness controlled
- Permanent flatness and wall thickness control
- Ready to Use: CleanRoom Pure<sup>®</sup>
- ANSI/ SLAS 2004 Standards
- Bottom shape: round (U)

## Physical Properties

Temperature Range: TreffLab Deep Well Plates withstand temperature range from PP: -80°C to autoclaving (121°C, 20 minutes, 100% humidity) according DIN EN 285

### Centrifuge forces:

*TreffLab 0.5 ml, 1.2 ml and 2.2 ml Deep Well Plates, PP or PS, have been developed to serve as «Sample preparation, assay and storage vessel» primarily. All Nolato Treff DWP are suitable for centrifugal applications with the following limits:*

*A) Using TreffLab Centrifugal Mat TreffLab Deep Well Plates withstand centrifugal g forces up to 6'000 RCF.*

*B) When no TreffLab<sup>®</sup> Centrifugal Mat is used, Nolato Treff AG do not to surpassed a centrifugal g force > 2000 RCF*

*However, Nolato Treff will not guarantee any centrifugal stability as since compliance with critical physical parameters are mandatory. In order to achieve such stability, i.e. proper counterbalance (> 0.1 gram), appropriate centrifugal swing plates, proper DWP positioning at swing plate, stress reduction of plate bottom by use of flexible support mat between DWP and swing plate is required. The homogeneity of DWP vial filling (ml) and the total sample weight per vial (g) within the 96 plate is also important, as well as a correct centrifugal operation.*

Overall this is technical information only. Please note that Treff cannot give any guarantee for centrifuge applications of its Deep Well Plates for the above mentioned reasons.