

# Cole-Parmer®

## DR-200 Series Rotator Drive Unit

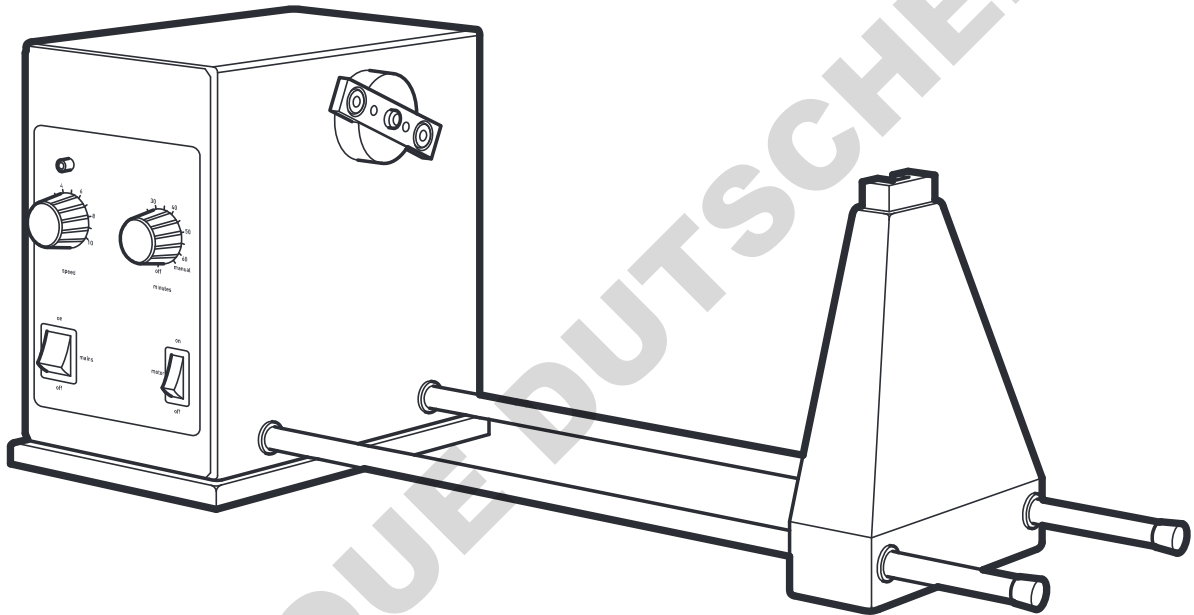

Instruction Manual  
ISTC1C4(S) Version 2.3

**Cole-Parmer®**  
essentials

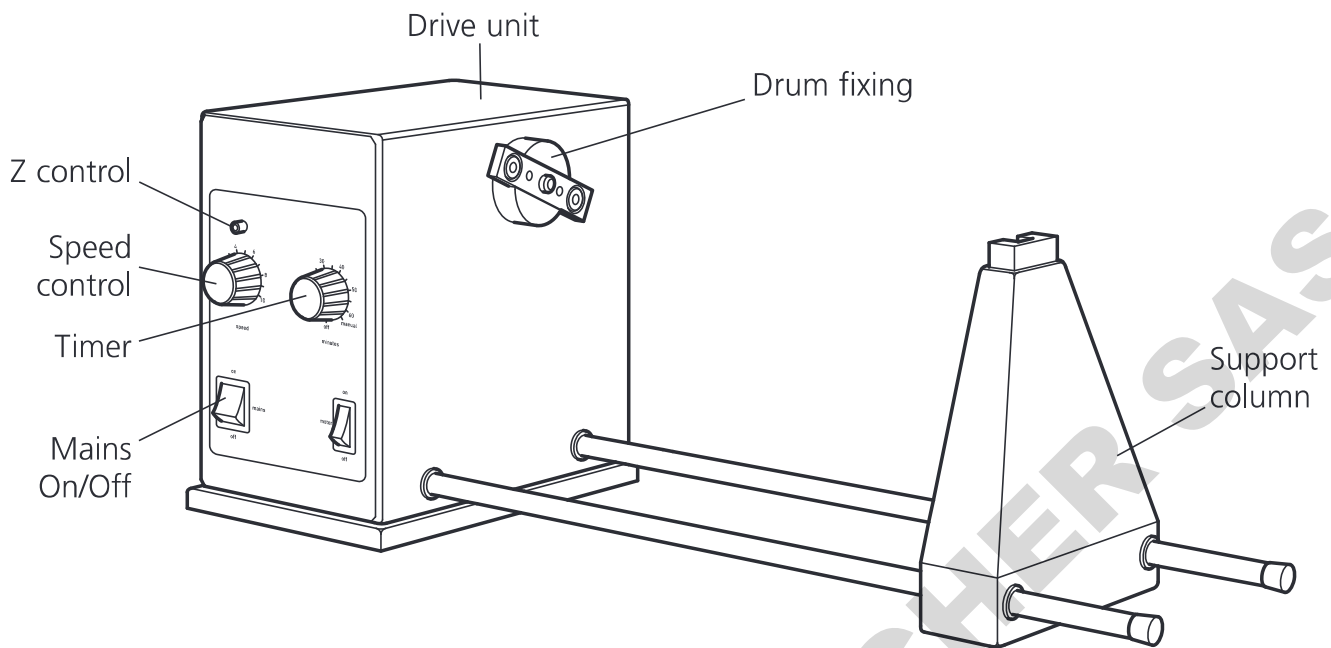

Fig. 1: DR-200 Drive unit

## Rotator

DR-200

Instructions for use

## Introduction

Thank you for purchasing this piece of Cole-Parmer equipment. To get the best performance from the equipment and for your own safety, please read these instructions carefully before use. Before discarding the packaging check that all parts are present and correct.

This equipment is designed to operate under the following conditions:

- ❖ For indoor use only
- ❖ Use in a well ventilated area
- ❖ Ambient temperature range +5°C to +40°C
- ❖ Altitude to 2000m
- ❖ Relative humidity not exceeding 80%
- ❖ Mains supply fluctuation not exceeding 10%
- ❖ Over-voltage category II IEC60364-4-443
- ❖ Pollution degree 2

If the equipment is not used in the manner described in this manual and with accessories other than those recommended by Antylia Scientific, the protection provided may be impaired.

# Electrical Installation



## THIS EQUIPMENT MUST BE EARTHED

**Before connection please ensure that the line supply corresponds to that shown on the rating plate.**

Model	Supply requirements	Power
DR-200	230V, 50Hz	50W

The DR-200 is supplied with two mains leads fitted with IEC plugs for connection to the instrument. One has a U.K. 3 pin plug and the other has a 2 pin "Schuko" plug for connection to the mains. Choose the lead appropriate for your electrical installation and discard the other. Should neither lead be suitable, take the lead with the U.K. plug and replace the plug with a suitable alternative. This involves cutting off the moulded plug, preparing the cable and connecting to the re-wireable plug in accordance with its instructions.

### THIS OPERATION SHOULD ONLY BE UNDERTAKEN BY A QUALIFIED ELECTRICIAN

**NOTE:** Refer to the equipment's rating plate to ensure that the plug and fusing are suitable for the voltage and wattage stated.

The wires in the mains cable are coloured as follows:

BROWN	- LIVE
BLUE	- NEUTRAL
GREEN/YELLOW	- EARTH

The instrument is fitted with an IEC socket at the rear for connection of the mains lead. The appropriate mains lead should be connected **BEFORE** connection to the mains supply.

Should the mains lead need replacement, a cable of 1mm<sup>2</sup> of harmonised code H05W-F connected to an IEC320 plug should be used.

### IF IN DOUBT CONSULT A QUALIFIED ELECTRICIAN

## Safety Advice Before Use

- ❖ The unit should be carried using two hands.
- ❖ Never move or carry the unit while it is in use or connected to the mains supply.
- ❖ DO NOT position the product so that it is difficult to access the ON/OFF switch or disconnect it from the mains supply using the mains plug.

- ❖ The mains outlet socket used should be located close to the equipment and readily identifiable and accessible to users.
- ❖ In the case of power interruption, a fault or mechanical failure, the unit will continue to operate on removal of fault.
- ❖ NEVER stop the rotation by hand and ALWAYS ensure that the rotator is evenly balanced.
- ❖ Mechanical energy can lead to breakage of glass vessels. Use with care.
- ❖ ALWAYS ensure there is sufficient free space around the rotator so that it does not come into contact with anything during use.
- ❖ DO NOT mix combustible liquids or use the equipment in hazardous atmospheres.

## General Description

The DR-200 is a drive unit with variable speed control that can be set between 6 and 60rpm. For added convenience it also has an analogue timer that can be set from 10 to 60 minutes. Alternatively the unit can be set for continuous operation. The DR-200 accepts one of five accessory drums that are designed to give different mixing actions.

## Operation

Refer to Fig. 1 to identify the parts and controls.

1. Assemble the drive unit and support column. Push the threaded ends of the two connecting rods through the holes in the support column and locate them into the corresponding two holes in the drive unit. Screw each connecting rod firmly into the drive unit.
2. Place the apparatus on a firm, level surface.
3. Attach the left hand fixing of the drum to the drum fixing on the drive unit.
4. Adjust the lateral position of the support column so that it is at the correct distance to accommodate the length of the drum shaft and secure in place with the thumb screw at the back.
5. Switch the mains On/Off and motor On/Off switches to On.
6. Turn the speed control knob until the desired rotation is seen.
7. For continuous operation, set the timer knob to Manual.
8. In order to mix for a given time, set the timer knob to the required time in minutes. When the set time is over, the unit will stop the rotation.

## Accessory drums

**STR4/1:** Designed for rotating tubes in an end-over-end movement. The STR4/1 consists of a square metal drum which can accommodate up to four plates fitted with clips for various size tubes.

All clip plates are interchangeable and may be fitted to any face of the drum. To fit the clip plate to the drum, insert the locking pins into the holes on any one face. Ensure that the button on the left hand end face of the drum is pressed in, flush with the drum. Press the clip plates well into the drum then push the button on the right hand face of the drum inwards to lock the clip plate in position.

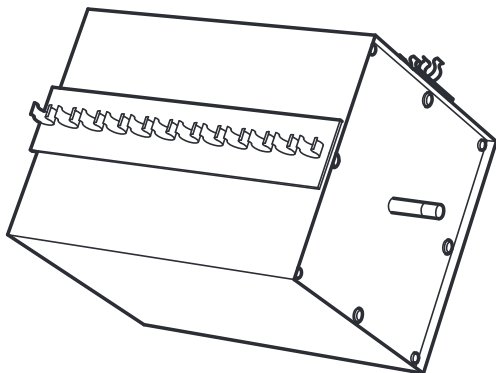

Fig. 2: STR4/1

**SRT4/2:** Designed to hold two x 250ml flasks or reagent bottles for end-over-end mixing. The vessels are securely held in place by a collar that fits around the neck of the flask or bottle and is secured by two washers.

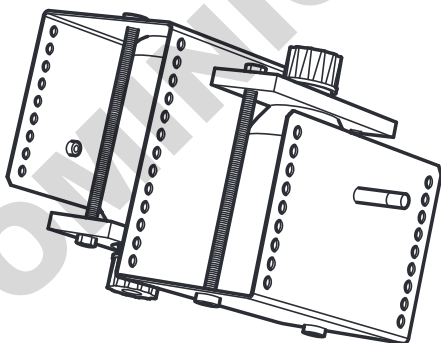

Fig. 3: STR4/2

**STR4/3:** Designed to hold a single vessel at a 45° angle so that it is rolled and turned end-over-end at the same time, resulting in a vigorous figure of 8 mixing action. The vessel is held firmly in place by strong Velcro® straps. The maximum vessel size is approximately 200mm in length, 120mm diameter.

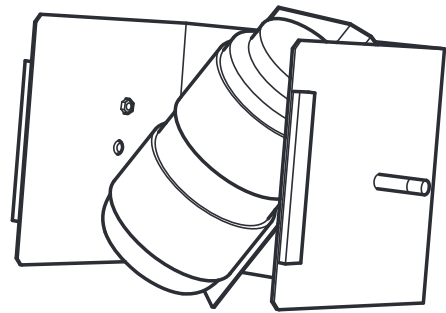

Fig. 4: STR4/3

**STR4/4:** Consists of a four segment Perspex® cradle. Each segment is fitted with a fully adjustable Velcro® strap to hold bottles and other containers up to 120mm in diameter and 300mm in length.

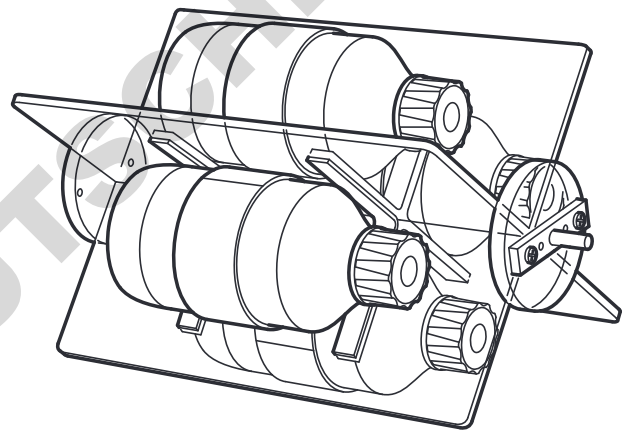

Fig. 5: STR4/4

**STR4/5:** Designed for thorough end-over-end mixing of 1.5ml microcentrifuge tubes. STR4/5 includes 4 racks, each of which can accommodate up to 60 tubes. Individual racks are easily removed by removing a locking knob and sliding the rack out of the cradle.

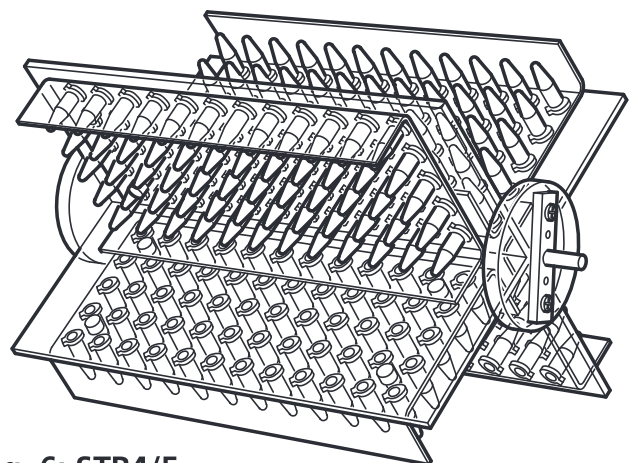

Fig. 6: STR4/5

## Maintenance & Servicing



**WARNING:** Ensure the unit is disconnected from the mains electricity supply before attempting maintenance or servicing.

Periodically clean the instrument using a damp cloth and mild detergent solution. Do not use harsh or abrasive cleaning agents.

**Any repairs or replacement of parts MUST be undertaken by suitably qualified personnel.**

For a comprehensive list of parts required by service engineers conducting internal repairs, please contact the Service Department, quoting both the model number and serial number:

Email: [cpsservice@antylia.com](mailto:cpsservice@antylia.com)  
Tel: +44 (0)1785 810475

**Only spare parts supplied or specified by Antylia Scientific or its agents should be used. Fitting of non-approved parts may affect the performance of the safety features designed into the instrument.** If in any doubt, please contact the Service Department of Antylia Scientific or the point of sale.

For any other technical enquiries, please contact the Technical Support Department:  
Email: [cpstechsupport@antylia.com](mailto:cpstechsupport@antylia.com)  
Tel: +44 (0)1785 810433.

## Spares and Accessories

Description	Catalogue Number
Drum to hold test tube clip plates	STR4/1
Clip plates for 12 x 12mm tubes (pair)	STR1/1
Clip plates for 10 x 16mm tubes (pair)	STR1/2
Clip plates for 8 x 19mm tubes (pair)	STR1/3
Clip plates for 7 x 24mm tubes (pair)	STR1/4
Drum with two platforms to hold flasks or bottles	STR4/2
Drum with figure of 8 mixing action	STR4/3
Drum with four segment cradle for bottles	STR4/4
Drum with four segment cradle for microfuge tubes	STR4/5
Spare rack for 60 x 1.5ml microfuge tubes	SW2/1

# Technical Specification

<b>DR-200</b>	
Rotation speed	6 to 60rpm
Timer	10 to 60 minutes or continuous
Maximum load	3kg
Power	230V, 50/60Hz
Dimensions (w x d x h) mm	650 x 250 x 250mm
Net weight	6.4kg
Electrical supply	230V, 50Hz, 50W

DOMINIQUE DUTSCHER SAS



This product meets the applicable CE Directives and UKCA Legislation for radio frequency interference and may be expected not to interfere with, or be affected by, other equipment with similar qualifications. We cannot be sure that other equipment used in its vicinity will meet these standards and so we cannot guarantee

that interference will not occur in practise. Where there is a possibility that injury, damage or loss might occur if equipment malfunctions due to radio frequency interference, or for general advise before use, contact the manufacturer.

Declaration of Conformity is available to view online at [www.stuart-equipment.com](http://www.stuart-equipment.com)

DOMINIQUE DUTSCHER SAS

**EU Representative address**

Antylia Scientific GmbH  
Futtererstraße 16  
97877 Wertheim  
Deutschland  
Tel: +49 9377 9203-0  
Email: [sales@coleparmer.de](mailto:sales@coleparmer.de)

**UK Representative address**

Antylia Scientific  
9 Orion Court  
Ambuscade Road  
Colmworth Business Park  
St. Neots  
PE19 8YX  
United Kingdom  
Tel: +44 (0) 1480 277339  
Email: [enquiries@antylia.com](mailto:enquiries@antylia.com)



# Ordering Information

Order No.	Series	Model	Legacy SKU
51600-02	DR-200	DR-200-120	STR4/120V/60
51600-06	DR-200	DR-200	STR4

Warranty Registration



## UK

T: +44 (0) 1480 272279  
E: uk.sales@antylia.com  
W: coleparmer.co.uk

## India

T: +9122 61394444  
E: info@coleparmer.in  
W: coleparmer.in

## Germany

T: +49 (0) 9377 92030  
E: de.sales@antylia.com  
W: coleparmer.de

## China

T: +1 847 549 7600  
E: sales@antylia.com  
W: coleparmer.com

## France

T: +33 (0) 1486 37800  
E: fr.sales@antylia.com  
W: coleparmer.fr

## USA

T: +1 847 549 7600  
E: sales@antylia.com  
W: coleparmer.com

## Italy

T: +39 (0) 284349215  
E: it.sales@antylia.com  
W: coleparmer.it

## Canada

T: +514 355 6100  
E: info@antylia.ca  
W: coleparmer.ca

## Other

T: +1 847 549 7600

**Cole-Parmer®**  
essentials

**Antylia Scientific Ltd.**

Beacon Road,  
Stone,  
Staffordshire,  
ST15 0SA,  
United Kingdom

