

pipetman®

User's Guide

EN





TABLE OF CONTENTS

INTRODUCTION | 3

Parts Checklist | 3

Good Laboratory Practice (GLP) Compliance | 3

Description | 4

Specifications | 4

SETTING THE VOLUME | 6

PIPETTING | 6

Fitting the Tips | 6

Pre-Wetting the Tips | 8

Aspirating | 8

Dispensing | 8

Guidelines for Good Pipetting | 9

ACCESSORIES | 10

TROUBLESHOOTING | 12

Leak Test | 13

MAINTENANCE | 13

Maintenance for Single Channel Models | 14

Maintenance for Multichannel Models | 15

CLEANING AND DECONTAMINATION | 16

SPARE PARTS | 18

WARRANTY | 20

NOTICE

Decreased pipetting forces are due to the design of the piston assembly, which includes a very high-quality lubricant (part number 5440011070). The use of any other lubricant voids the warranty of this pipette.



Chapter 1

INTRODUCTION

PIPETMAN®, recognized as the pipetting standard, is a fully adjustable, air-displacement pipette that uses disposable tips.

PIPETMAN combines its legendary accuracy, precision and durability with easy pipetting and handling.

PIPETMAN offers a large range of accurate and precise pipettes with optimized pipetting and purge forces for hours of pipetting

Eight single channel models cover a volume range from 0.2 µL to 10 mL.

Eight multichannel models cover a volume range from 1 µL to 300 µL.

Parts Checklist

After unpacking the pipette, verify that the following items were included and are undamaged:

Single Channel Models

- PIPETMAN®
- Quick Guide
- Safety bag
- Certificate of Conformity (including barcode sticker)
- Dual-position adapter (for P2 and P10 models only)

Multichannel Models

- PIPETMAN®
- Quick Guide
- Safety bag
- Certificate of Conformity (including barcode sticker)
- Ejector spacers for D10 tips (for Px10 models only)

Good Laboratory Practice (GLP) Compliance

The **serial number** is engraved on the body of the pipette. It provides unique identification of your pipette and the manufacturing date.

Ex:

A	A	50001
Year	Month	Production number

YEAR	CODE
2022	T
2023	U
2024	W
2025	X
2026	Y
2027	Z

MONTH	CODE
January	A
February	B
March	C
April	D
May	E
June	G
July	H
August	J
September	K
October	L
November	M
December	N

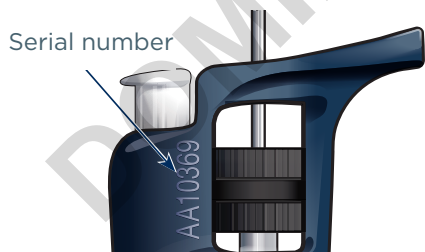

Figure 1
Serial number and identification

The **barcode** on the box and the Certificate of Conformity provides traceability of your pipette.

Description



Figure 2

PIPETMAN® multichannel and single channel model components

Please refer to the following chapters for a full description of the different parts and functions of the pipette.

Specifications

PIPETMAN® is a high quality pipette that offers excellent accuracy and precision. The data provided in the [Gilson Maximum Permissible Errors](#) table were obtained using PIPETMAN® DIAMOND Tips. These values are guaranteed only when genuine PIPETMAN DIAMOND Tips are used.

Each pipette is inspected and validated by qualified technicians in accordance with the Gilson Quality System. Gilson declares that its manufactured pipettes comply with the requirements of the ISO 8655 standard by type testing.

The adjustment is carried out under strictly defined and monitored conditions (ISO 8655-6).

NOTICE

The data given in the tables conform to the ISO 8655-2 standard. With a precise pipetting technique, the P2 model may be used to aspirate volumes as low as 0.1 µL and the P10 model as low as 0.5 µL.

PIPETMAN® is equipped with a stainless steel tip ejector and can also be used with a plastic tip ejector, which is available as an accessory (refer to [ACCESSORIES](#) on page 10).

Maximum Permissible Errors



PIPETMAN® SINGLE CHANNEL														
Model	PIPETMAN® DIAMOND Tips		Part Number	Nominal Volume (µL)	Volume (µL)	Volume (%)	Maximum Permissible Errors							
							Gilson				ISO 8655-2 (Table 1)			
							Systematic Error (µL)	Random Error (µL)	Systematic Error (%)	Random Error (CV)*	Systematic Error (µL)	Random Error (µL)	Systematic Error (%)	Random Error (CV)*
P2	D10 DL10	DF10ST DFL10ST	F144054M	2	0.2	10	± 0.024	≤ 0.012	± 12.0	≤ 6.0	± 0.050	≤ 0.040	± 25	≤ 20
					0.5	25	± 0.025	≤ 0.012	± 5.0	≤ 2.4	± 0.050	≤ 0.040	± 10	≤ 8
					1	50	± 0.025	≤ 0.012	± 2.5	≤ 1.2	± 0.050	≤ 0.040	± 5.0	≤ 4.0
					2	100	± 0.030	≤ 0.014	± 1.5	≤ 0.7	± 0.050	≤ 0.040	± 2.5	≤ 2.0
P10**	D10 DL10	DF10ST DFL10ST	F144055M	10	1	10	± 0.025	≤ 0.012	± 2.5	≤ 1.2	± 0.120	≤ 0.080	± 12	≤ 8.0
					5	50	± 0.075	≤ 0.030	± 1.5	≤ 0.6	± 0.120	≤ 0.080	± 2.4	≤ 1.6
					10	100	± 0.100	≤ 0.040	± 1.0	≤ 0.4	± 0.120	≤ 0.080	± 1.2	≤ 0.8
P20	D200	DF30ST	F144056M	20	2	10	± 0.10	≤ 0.030	± 5.0	≤ 1.5	± 0.20	≤ 0.100	± 10	≤ 5.0
					5	25	± 0.10	≤ 0.040	± 2.0	≤ 0.8	± 0.20	≤ 0.100	± 4.0	≤ 2.0
					10	50	± 0.10	≤ 0.050	± 1.0	≤ 0.5	± 0.20	≤ 0.100	± 2.0	≤ 1.0
					20	100	± 0.20	≤ 0.060	± 1.0	≤ 0.3	± 0.20	≤ 0.100	± 1.0	≤ 0.5
P100	D200	DF100ST	F144057M	100	10	10	± 0.35	≤ 0.10	± 3.5	≤ 1.0	± 0.80	≤ 0.300	± 8.0	≤ 3.0
					50	50	± 0.40	≤ 0.12	± 0.8	≤ 0.24	± 0.80	≤ 0.300	± 1.6	≤ 0.60
					100	100	± 0.80	≤ 0.15	± 0.8	≤ 0.15	± 0.80	≤ 0.300	± 0.80	≤ 0.30
P200	D200 D300	DF200ST DF300ST	F144059M	200	20	10	± 0.50	≤ 0.20	± 2.5	≤ 1.0	± 1.60	≤ 0.600	± 8.0	≤ 3.0
					100	50	± 1.00	≤ 0.25	± 0.8	≤ 0.25	± 1.60	≤ 0.600	± 1.6	≤ 0.60
					200	100	± 1.60	≤ 0.30	± 0.8	≤ 0.15	± 1.60	≤ 0.600	± 0.80	≤ 0.30
P1000	D1000 D1200	DF1000ST DF1200ST	F144059M	1000	100	10	± 3.0	≤ 0.6	± 3.0	≤ 0.6	± 8.0	≤ 3.0	± 8.0	≤ 3.0
					500	50	± 4.0	≤ 1.0	± 0.8	≤ 0.2	± 8.0	≤ 3.0	± 1.6	≤ 0.60
					1000	100	± 8.0	≤ 1.5	± 0.8	≤ 0.15	± 8.0	≤ 3.0	± 0.80	≤ 0.30
P5000***	D5000		F144066	5000	500	10	± 12	≤ 3	± 2.4	≤ 0.6	± 40.0	≤ 15.0	± 8.0	≤ 3.0
					2500	50	± 15	≤ 5	± 0.6	≤ 0.2	± 40.0	≤ 15.0	± 1.6	≤ 0.60
					5000	100	± 30	≤ 8	± 0.6	≤ 0.16	± 40.0	≤ 15.0	± 0.80	≤ 0.30
P10mL***	D10mL		F144067	10000	1000	10	± 30	≤ 6	± 3.0	≤ 0.6	± 60.0	≤ 30.0	± 6.0	≤ 3.0
					5000	50	± 40	≤ 10	± 0.8	≤ 0.2	± 60.0	≤ 30.0	± 1.2	≤ 0.60
					10000	100	± 60	≤ 16	± 0.6	≤ 0.16	± 60.0	≤ 30.0	± 0.60	≤ 0.30

PIPETMAN® MULTICHANNEL														
Model	PIPETMAN® DIAMOND Tips		Part Number	Nominal Volume (µL)	Volume (µL)	Volume (%)	Maximum Permissible Errors							
							Gilson				ISO 8655-2 (Table 2)			
							Systematic Error (µL)	Random Error (µL)	Systematic Error (%)	Random Error (CV)*	Systematic Error (µL)	Random Error (µL)	Systematic Error (%)	Random Error (CV)*
P8x10	D10 DL10	DF10ST DFL10ST	F144068	10	1	10	± 0.08	≤ 0.05	± 8.0	≤ 5.0	± 0.24	≤ 0.16	± 24	≤ 16
					5	50	± 0.20	≤ 0.10	± 4.0	≤ 2.0	± 0.24	≤ 0.16	± 4.8	≤ 3.2
P12x10			F144069		10	100	± 0.20	≤ 0.10	± 2.0	≤ 1.0	± 0.24	≤ 0.16	± 2.4	≤ 1.6
P8x20	DL10 D200	DFL10ST DF30ST	F144070	20	2	10	± 0.10	≤ 0.08	± 5.0	≤ 4.0	± 0.40	≤ 0.20	± 20	≤ 10
					10	50	± 0.20	≤ 0.10	± 2.0	≤ 1.0	± 0.40	≤ 0.20	± 4.0	≤ 2.0
P12x20			F144071		20	100	± 0.40	≤ 0.20	± 2.0	≤ 1.0	± 0.40	≤ 0.20	± 2.0	≤ 1.0
P8x200	D200 D300	DF200ST DF300ST	F144072	200	20	10	± 0.50	≤ 0.25	± 2.5	≤ 1.25	± 3.20	≤ 1.20	± 16	≤ 6.0
					100	50	± 1.00	≤ 0.40	± 1.0	≤ 0.40	± 3.20	≤ 1.20	± 3.2	≤ 1.2
P12x200			F144073		200	100	± 2.00	≤ 0.50	± 1.0	≤ 0.25	± 3.20	≤ 1.20	± 1.6	≤ 0.60
P8x300	D200 D300	DF200ST DF300ST	F144074	300	30	10	± 1.00	≤ 0.35	± 3.33	≤ 1.17	± 4.8	≤ 1.8	± 16	≤ 6.0
					150	50	± 1.50	≤ 0.60	± 1.0	≤ 0.4	± 4.8	≤ 1.8	± 3.2	≤ 1.2
P12x300			F144075		300	100	± 3.00	≤ 1.00	± 1.0	≤ 0.33	± 4.8	≤ 1.8	± 1.6	≤ 0.60

*CV means Coefficient of Variation (%)

Gilson maximum permissible errors are guaranteed only when PIPETMAN® pipettes are used with the recommended PIPETMAN® DIAMOND Tips.

**P10 model can be used up to 0.5 µL.

***P5000 and P10mL do not have tip ejectors.



SETTING THE VOLUME

The volume of liquid to be aspirated is set using the volume display. The dial colors are either black or red to indicate the position of the decimal point, depending on the model (refer to Figure 3).

The volume is set by turning the thumbwheel or the push button (refer to Figure 4). The push button makes it easier and quicker to set volumes, especially when wearing gloves. The thumbwheel may be turned using only one hand to slowly reach the required setting.

MODEL	COLOR OF VOLUMETER NUMBERS		
	BLACK	RED	INCREMENT
P2	μL	0.01 μL	0.002 μL
P10 - P20 - PX10 - PX20	μL	0.1 μL	0.02 μL
P100 - P200 - PX200 - PX300	μL	-	0.2 μL
P1000	0.01 mL	mL	0.002 mL
P5000	0.01 mL	mL	0.002 mL
P10mL	mL	0.1 mL	0.02 mL

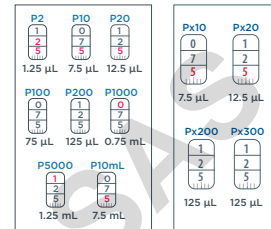

Figure 3
Dial colors by model

To achieve maximum accuracy when setting the volume, proceed as follows:

- When **decreasing** the volume setting, slowly reach the required setting, making sure to not overshoot the mark.
- When **increasing** the volume setting, pass the required value by 1/3 of a turn and then slowly decrease to reach the volume, making sure to not overshoot the mark.

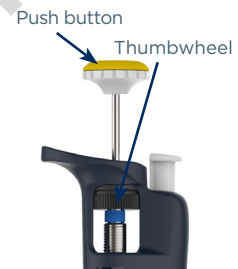

Figure 4
Location of push button and thumbwheel

PIPETTING

While many brands of tips can be used with PIPETMAN®, it is recommended to use PIPETMAN® DIAMOND Tips with PIPETMAN® for optimum performance. These tips are made from pure polypropylene. Plastic tips are for a single application—they should not be cleaned for reuse.

Fitting the Tips

Single Channel Models

To fit a new PIPETMAN DIAMOND Tip, push the tip holder into the tip using a slight twisting motion to ensure a firm, airtight seal.

PIPETMAN DIAMOND Tip Compatibility for Single Channel Variable Volume Models	
P2, P10	D10, DL10, DF10ST, DFL10ST
P20	D200, DF30ST
P100	D200, DF100ST
P200	D200, D300, DF200ST, DF300ST
P1000	D1000, D1200, DF1000ST, DF1200ST
P5000	D5000
P10mL	D10mL

Figure 5
PIPETMAN® DIAMOND Tip compatibility chart for single channel models



NOTICE

D5000 and D10mL PIPETMAN DIAMOND tips do not have any filter. P5000 and P10mL models are sold with a bag of 10 filters. Bags of filters are also available as accessories. (refer to Accessories on page 10).

The filters, made of polyethylene, offer the same properties as the filters which are inside the PIPETMAN DIAMOND filter tips. They maintain the pipette's original accuracy and precision by creating an efficient barrier to aerosols or corrosive vapors such as acids which could damage mechanical parts.

Insert the filter directly in the pipette tip holder.

Change the filter every day or more frequently depending on the intensity of use and/or concentration of the solution.

Filters are not autoclavable and must be disposed of after use.

Fitting the Tips on P2 and P10 models

NOTE

For the P2 and P10 models, a dual-position adapter (plastic) is required to fit DL10 tips (long tips) or D10 tips (short tips). The metallic rod of the tip ejector is shaped so the adapter may be clipped to it in either position.

P2 and P10 models are delivered with the adapter in place, ready to use DL10 tips. If D10 tips are used, the adapter must be repositioned in the shorter slot as follows:

1. Pull the adapter down from the metallic rod.
2. Turn the adapter 180°.
3. Refit the adapter so the end of the metallic rod engages the shorter slot of the adapter



Short tips Long tips

NOTE

The dual-position adapter is autoclavable.

Figure 6
Dual-position adapter for P2 and P10 with stainless steel tip ejector

An autoclavable tip ejector extension can be ordered as an accessory for P2 and P10 equipped with a plastic tip ejector (part number F107027; refer to [ACCESSORIES](#) on page 10).

To fit an extension to plastic ejector:

1. Slide the extension over the tip holder.
2. Push the extension firmly onto the end of the tip ejector until it clicks into place.

To remove an extension from plastic ejector:

1. Gently twist the extension.
2. Pull it away from the pipette.



Multichannel models

PIPETMAN® DIAMOND Tips are best fitted with the ROCKY RACK technique, invented by Gilson, available only in our TIPACK and TOWERPACK.



Figure 7
ROCKY RACK technique

PIPETMAN® DIAMOND Tip Compatibility for Multichannel Models	
P8x10, P12x10	D10*, DL10, DF10, DFL10
P8x20, P12x20	DL10, DFL10, DF30, D200
P8x200, P12x200	D200, D300, DF200, DF300
P8x300, P12x300	D200, D300, DF200, DF300

* Using the broad ejector spacer D10, you can adapt a D10 tip (see above).

Figure 8
PIPETMAN DIAMOND Tips compatibility chart for multichannel models



Ejector Spacer for PIPETMAN® 10 µL Multichannel Models

According to the tip used, D10 or DL10, you may have to exchange the ejector spacer.

The broad one is dedicated to D10, and the small one is dedicated to DL10.

- Remove the tip ejector, keeping both ejector locks depressed. Pull the tip ejector down.
- Gently press the tabs from the ejector spacer and remove it from the tip ejector.
- Insert the alternative ejector spacer and click it to the tip ejector.
- To refit the tip ejector, gently re-insert the tip ejector vertically into the rails of the ejector support.

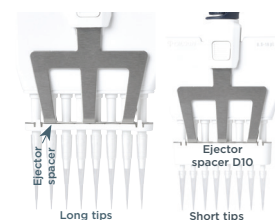

Figure 9
Ejector spacer location

PIPETMAN® DIAMOND Tips are best fitted with the ROCKY RACK technique, invented by Gilson, available only in our TIPACK and TOWERPACK.

Pre-Wetting the Tips

Pre-wetting the tips before pipetting helps prepare the tips for the best pipetting performance. Ideally, the pre-wet includes both immersing the tip in the liquid and performing one pipetting step.

Pre-wetting the tips helps ensure that volumes that your pipette will achieve accuracy and precision within specifications.

Aspirating

1. Press the push button to the **first stop** (this corresponds to the set volume of liquid).
2. Hold the pipette vertically and immerse the tip in the liquid (refer to [Guidelines for Good Pipetting](#) on page 9).
3. Release the push button slowly and smoothly (to the **top** position) to aspirate the set volume of liquid. Wait one second (refer to [Guidelines for Good Pipetting](#) on page 9) and then withdraw the pipette-tip from the liquid.
4. You may wipe any droplets away from the outside of the tip using a medical wipe, however, if you do so, take care to avoid touching the tip's orifice.

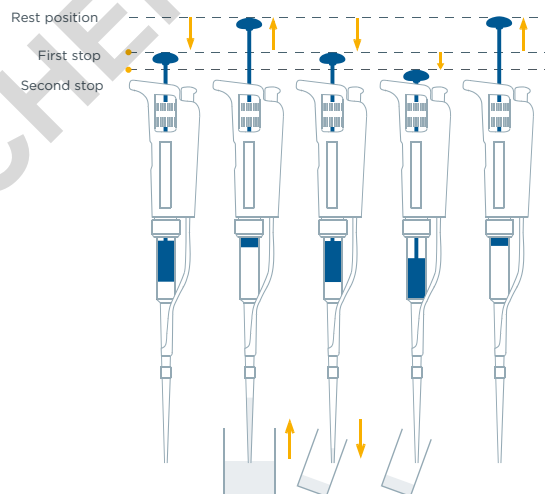

Figure 10
Pipetting motion - aspirate and dispense

Dispensing

1. Place the end of the tip against the inside wall of the recipient vessel (at an angle of 10° to 40°).
2. Press the push button slowly and smoothly to the **first stop**.
3. Wait for at least one second, then press the push button to the **second stop** to expel any residual liquid from the tip. Keep the push button pressed fully down and (while removing the pipette) draw the tip along the inside surface of the vessel.
4. Release the push button smoothly. Eject the tip by pressing firmly on the tip ejector button.



Guidelines for Good Pipetting

Make sure that you operate the push button slowly and smoothly.

When aspirating, keep the tip at a constant depth below the surface of the liquid (refer to the table below).

IMMERSION DEPTH AND WAIT TIME		
MODEL	IMMERSION DEPTH (MM)	WAIT TIME (SECONDS)
P2	1	1
P10 - Px10	1	1
P20 - Px20	2-3	1
P100 - Px200 - Px300	2-4	1
P200	2-4	1
P1000	2-4	2-3
P5000	3-6	4-5
P10mL	5-7	4-5

- Change the tip before aspirating a different liquid, sample, or reagent.
- Change the tip if a droplet remains at the end of the tip from the previous pipetting operation.
- Pre-wet each new tip with the liquid to be pipetted.
- Liquid should never enter the tip holder.
To prevent this:
 - Press and release the push button slowly and smoothly.
 - Never turn the pipette upside down.
 - Never lay the pipette on its side when there is liquid in the tip.
- If you use the same tip with a larger volume, pre-wet the tip.
- For volatile solvents, you should saturate the air cushion of your pipette by aspirating and dispensing the solvent repeatedly before aspirating the sample.
- When the temperature of the liquid is different from the ambient temperature, pre-wet the tip several times before use.
- You may remove the tip ejector (refer to [MAINTENANCE](#) on page 13) to aspirate from very narrow tubes.
- After pipetting acids or other corrosive liquids that emit vapors, remove the tip ejector and the tip holder; and then rinse, dry, and lubricate the piston (refer to [MAINTENANCE](#) on page 13). For the model P1000, you can increase the lifetime of the piston by using a specific tip holder equipped with a filter (refer to [ACCESSORIES](#) on page 10).
- Do not pipette liquids with temperatures above 70°C or below 4°C. The pipette can be used between 4° and 40°C, but the specifications may vary according to the temperature (refer to [Maximum Permissible Errors](#) on page 5).

NOTICE

It is recommended to regularly verify the volume displayed on the dial while pipetting. PIPETMAN should be held in the vertical position.



Chapter 4

ACCESSORIES

To make pipetting more comfortable and more convenient, Gilson has developed several accessories:

DESCRIPTION	PART NUMBER
Plastic Ejector P2/P10 with adapter	F107027
Plastic Ejector P20	F107028
Plastic Ejector P100	F107029
Plastic Ejector P200	F107030
Plastic Ejector P1000	F107031



Plastic Tip Ejector

Pipette stands allow users to store pipettes vertically to avoid the possibility of liquid running back into the pipette.

DESCRIPTION	PART NUMBER
CARROUSEL™ Pipette Stand (7 pipettes)	F161401
TRIO™ Stand (3 pipettes)	F161405
Universal Multichannel Stand*	F161417
SINGLE™ Pipette Holder	F161406

CARROUSEL™



Universal Multichannel Stand



TRIO™



SINGLE™



*Universal multichannel stand is for multichannel models only.

To identify or personalize your pipette, COLORIS™ Identification Clips are available.

DESCRIPTION	PART NUMBER
COLORIS Clips (mixed colors set of 10)	F161301
COLORIS Clips (red, set of 10)	F161302
COLORIS Clips (yellow, set of 10)	F161303
COLORIS Clips (green, set of 10)	F161304
COLORIS Clips (blue, set of 10)	F161305
COLORIS Clips (white, set of 10)	F161306



With The JIMMY™ Microtube Opener, a hands-free microtube opener, you can open both snap-cap and screw-cap microtubes.

DESCRIPTION	PART NUMBER
JIMMY Microtube Opener (set of 3)	F144983



For P5000 and P10mL models, disposable filters maintain the pipette's original accuracy and precision by creating an efficient barrier to aerosols or corrosive vapours such as acids which could damage mechanical parts.

DESCRIPTION	PART NUMBER
Bag of 10 Filters for P5000/P10mL	F161280
Bag of 100 Filters for P5000/P10mL	F161241



PIPETMAN® COMFORT HANDLE models reduce the force needed to grip the pipette for maximum comfort.

DESCRIPTION	PART NUMBER
PIPETMAN® COMFORT HANDLE (pack of 3, blue)	F161486
PIPETMAN® COMFORT HANDLE (pack of 3, white)	F161488
PIPETMAN® COMFORT HANDLE (pack of 50, blue)	F161485
PIPETMAN® COMFORT HANDLE (pack of 50, white)	F161487
PIPETMAN® COMFORT HANDLE (stickers, 120)	F161499



DOMINIQUE DUTSCHER SAS



TROUBLESHOOTING

A quick inspection of the pipette may help you detect a potential problem.

NOTE

You may download the Two Minute Inspection Poster from the Gilson website (www.gilson.com). The poster describes how to perform a quick diagnosis of your pipette.

WARNING

Before returning any pipette to your local Gilson Service Center, ensure that it is completely free of chemical, biological, or radioactive contamination (refer to [CLEANING AND DECONTAMINATION](#) on page 16). Please use the included safety bag to return the pipette to your local Gilson Service Center.

Troubleshooting Table

The following table may help you identify and correct the potential problem you might encounter.

NOTE

Please make sure the tips are correctly fitted. Refer to [Fitting the Tips](#) on page 6.

For Single Channel Variable, Fixed Volume, and Multichannel Models

Symptom	Possible Cause	Action	Model*
Pipette is leaking sample	Damaged tip holder	Replace the tip holder	S
	Worn O-ring or seal	Replace both parts and lubricate	S
Pipette will not aspirate	Worn O-ring	Replace both parts and lubricate	S
	Damaged tip holder	Replace the tip holder	S
	Connecting nut is loose	Tighten connecting nut	S+M
	Damaged or corroded piston	Return pipette to supplier	S
	Improper repair or assembly	Refer to page 13 - MAINTENANCE	S
Pipette volume is inaccurate	Improper repair or assembly	Refer to page 13 - MAINTENANCE	S
	Connecting nut is loose	Tighten connecting nut	S+M
	Tip holder is loose	Tighten connecting nut	S
	Incorrect operator technique	Operator training	S+M
	Damaged or corroded piston(s)	Return pipette to supplier	S
	Damaged tip holder(s)	Replace the tip holder(s)	S
	Worn O-ring or seal	Replace both parts and lubricate	S
Tips fall off or do not fit correctly	Low quality tips	Use PIPETMAN DIAMOND Tips	S+M
	Damaged tip holder(s)	Replace the tip holder(s)	S+M
	Damaged tip ejector	Replace the tip ejector	S+M
	Dirty tip holder	Clean the tip holder with isopropanol or ethanol	S+M
	The tip ejector is loose	Assemble the tip ejector properly	S
	The ejector lock is misaligned	Align the ejector lock	S
Pipetting seize up	Piston needs lubricant	Lubricate piston assembly	S

*S: Single channel pipettes / M: Multichannel pipettes

NOTE

If you cannot solve the problem, contact your local Gilson-authorized Service Center.



Leak Test

This test may be performed at any time to check that the pipette does not leak, especially after performing a maintenance or decontamination procedure. If a pipette fails this test, replace the O-ring and seal.

After making sure that the pipette is correctly reassembled, repeat this test.

For the P2 to P200 Models

1. Fit a PIPETMAN® DIAMOND Tip.
2. Set the pipette to the maximum volume given in the specifications and pre-wet.
3. Aspirate the set volume from a beaker of distilled water.
4. Maintain the pipette in the vertical position and wait for 20 seconds.
 - If a water droplet appears at the end of the tip, there is a leak.
 - If you see no droplet, re-immers the tip below the surface of water. The water level inside the tip should remain constant. If the level goes down, there is a leak.

For the P1000, P5000, and P10mL Models

1. Fit a PIPETMAN DIAMOND Tip.
2. Set the pipette to the maximum volume given in the specifications.
3. Aspirate the set volume from a beaker of distilled water.
4. Maintain the pipette in the vertical position and wait for 20 seconds.
 - If a water droplet appears at the end of the tip, there is a leak.

For the Multichannel Models (P8x, P12x)

1. Fit the PIPETMAN® DIAMOND Tip.
2. Set the pipette to the maximum volume given in the specifications and pre-wet.
3. Aspirate the set volume from a reagent reservoir of distilled water.
4. Maintain the pipette in the vertical position and wait for 20 seconds.
 - If a water droplet appears at the end of the tip, there is a leak.
 - For volumes below 200 µL, if you see no droplets, re-immers the tip below the surface of water.
 - The water level inside the tip should remain constant. If the level goes down, there is a leak.

Chapter 6

MAINTENANCE

Routine maintenance will help keep your pipette in good condition, ensuring a continued high level of performance.

NOTICE

Gilson recommends maintenance and calibration at least annually, more frequently as needed, depending on use. The instructions provided below detail how to perform some basic maintenance yourself. Please contact your local Gilson service provider ([Click here to find your local Gilson representative](#)) to have Gilson provide maintenance and calibration for you or to ask any service related questions.

Maintenance is limited to:

- Cleaning or decontamination (refer to [CLEANING AND DECONTAMINATION](#) on page 16).
- Replacing spare parts
- Greasing the piston assembly

Maintenance for Single Channel Models

PIPETMAN P2 and P10 should not be disassembled, so you can only replace the push button, tip ejector, and its dual position adapter. With these pipettes if the tip holder is damaged, the piston may also be damaged.



NOTICE After replacing any parts, you should verify the performance of your pipette following the verification procedure available on the Gilson website (www.gilson.com). If the pipette needs to be readjusted, please contact your local Gilson Service Center.

Changing the Tip Ejector for Single Channel Models

To remove:

- 1 Push the ejection button.
- 2 Laterally push the tip ejector.
- 3 Slide and remove the tip ejector.



To refit:

- 1 Push the ejection button.
- 2 Slide the tip ejector along the tip holder.
- 3 Push laterally to clip the tip ejector on the body of the pipette.

Changing the Tip Holder - No Tools Required

1. Remove the tip ejector (refer to [Changing the Tip Ejector for Single Channel Models](#) on page 14).
2. Unscrew the connecting nut by turning it counterclockwise.
3. Carefully separate the lower and upper parts.
4. Remove the piston assembly and the seals.
5. Clean, autoclave, or replace the tip holder.
6. If necessary, lightly lubricate the piston and its seals (refer to [Servicing the Piston Assembly](#) on page 14).
7. Reassemble the pipette (refer to the Figure 12 on page 14).
8. Tighten the connecting nut (turn clockwise)
9. Refit the tip ejector (refer to [Changing the Tip Ejector for Single Channel Models](#) on page 14).

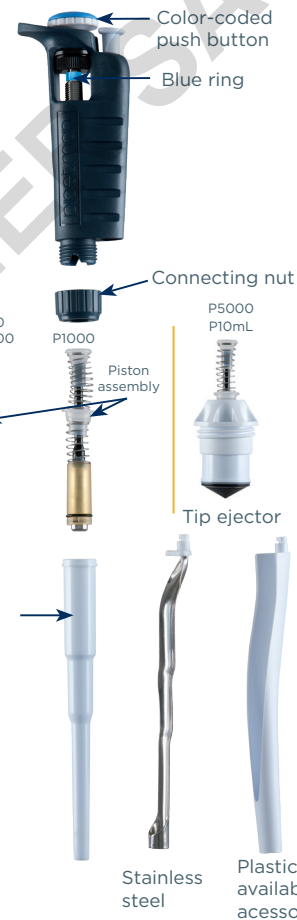

Servicing the Piston Assembly

You may remove the piston assembly for cleaning purposes only. If the piston assembly is changed, the pipette must be adjusted and calibrated by a trained technician in a Gilson-authorized Service Center. Because P2 and P10 models contain miniaturized parts, it is best not to disassemble these pipettes yourself.

NOTICE The piston assembly must **not** be autoclaved.

Figure 11

Disassembled PIPETMAN®, with different piston assemblies

1. Remove the tip ejector (refer to [Changing the Tip Ejector for Single Channel Models](#) on page 14).
2. Unscrew the connecting nut by turning it clockwise.
3. Carefully separate the lower and upper parts.
4. Remove the piston assembly and the seals.
5. Leave the piston exposed, clean it with isopropanol or ethanol, and lubricate lightly. **For P100, P200, and P1000** models, lubricate only the internal part of the piston and the seals. **For P5000 and P10mL**, lubricate the tip of the piston, disassemble the seals, and lubricate their internal part.



NOTICE

Optimized pipetting forces are due to the design of the piston assembly, which includes a very high-quality lubricant (part number 5440011070). The use of any other lubricant voids the warranty of this pipette.

6. Reassemble the pipette (refer to Figure 12 on page 14).
7. Tighten the connecting nut (turn counterclockwise).
8. Refit the tip ejector (refer to [Changing the Tip Ejector for Single Channel Models](#) on page 14).

Changing the Seal Guide (or Seal)

The O-ring and seal on the piston must not be autoclaved. If worn or damaged in any way (chemical or mechanical), they must be replaced. Because the models P2 and P10 contain miniaturized parts, it is best not to disassemble these pipettes yourself. Please contact your local Gilson Service Center.

The dimensions of the O-ring vary depending on the model of pipette.

1. Remove the tip ejector (refer to [Changing the Tip Ejector for Single Channel Models](#) on page 14).
2. Unscrew the connecting nut by turning it counterclockwise.
3. Carefully separate the lower and upper parts.
4. Remove the piston assembly, O-ring, and seal.
5. If necessary, clean the piston and replace the seal. Lightly lubricate both seal and piston. Remember to replace the seal and O-ring in the correct order.
6. Reassemble the pipette (refer to the Figure 12 on page 14).
7. Tighten the connecting nut (turn counterclockwise).
8. Refit the tip ejector (refer to [Changing the Tip Ejector for Single Channel Models](#) on page 14).

Maintenance for Multichannel Models

Routine maintenance will help keep your pipette in good condition, ensuring a continued high level of performance.

Maintenance is limited to:

- Cleaning or decontamination (refer to [CLEANING AND DECONTAMINATION](#) on page 16).
- Replacing spare parts
- Greasing the piston assembly

Changing the Tip Ejector for Multichannel Model

To remove the tip ejector, keep both ejector locks depressed. Pull the tip ejector down.

To refit the tip ejector, gently re-insert the tip ejector vertically into the rails of the ejector support.

Pull lightly on the tip ejector to check the position.

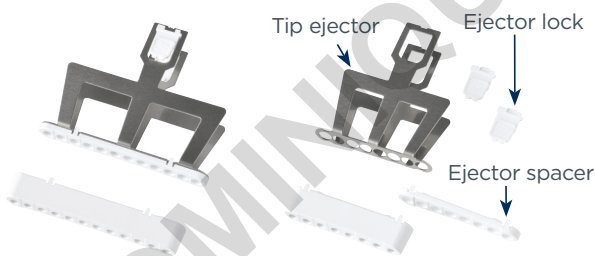

Figure 12

PIPETMAN® multichannel tip ejector and ejector spacers



CLEANING AND DECONTAMINATION

PIPETMAN® is designed so that the parts normally in contact with liquid contaminants can easily be cleaned and decontaminated. However, because the models P2 and P10 contain miniaturized parts, it is best not to disassemble these pipettes yourself. Please contact your local Gilson Service Center.

NOTICE

You can refer to the decontamination procedure available on the Gilson website (www.gilson.com).
Liquid must never enter the upper part (handle) of any pipette.

Cleaning for Single Channel Models

The pipette must be cleaned, as described below, before it is decontaminated. Soap solution is recommended for cleaning PIPETMAN®.

External

1. Remove the tip ejector (refer to [Changing the Tip Ejector for Single Channel Models](#) on page 14).
2. Wipe the entire pipette and the tip ejector with a soft cloth or lint-free tissue soaked with soap solution to remove all dirty marks. If the pipette is very dirty, a brush with soft plastic bristles may be used.
3. Wipe the entire pipette and the tip ejector with a soft cloth or lint-free tissue soaked with distilled water.
4. Refit the tip ejector and allow the pipette to dry.

Internal

Only the following components can be immersed in a cleaning solution: connecting nut, tip ejector, tip holder, piston assembly, seal, and O-ring.

1. Disassemble the pipette (refer to Figure 12 on page 14).
2. Set aside the upper part in a clean, dry place.
3. Clean the individual components of the lower part of the pipette using an ultrasonic bath (20 minutes at 50°C) or with a soft cloth and brushes.

NOTE

The piston assembly and seals must be degreased with isopropanol or ethanol before being immersed in the ultrasonic bath. Small round brushes with soft plastic bristles may be used to clean the interior of the tip holder.

1. Rinse the individual components with distilled water.
2. Let the parts dry by evaporation or wipe them with a clean soft cloth or lint-free tissue.
3. Reassemble the pipette as described (refer to Figure 12 on page 14).

Cleaning for Multichannel Models

Only the following components can be immersed in a cleaning solution: tip ejector, ejector locks, and ejector spacer.

1. Remove the tip ejector and the ejector spacer.
2. Immerse the tip ejector, ejector locks, and ejector spacer in the cleaning solution or wipe them with a soft cloth or lint-free tissue soaked with the cleaning solution.
3. Rinse the components with distilled water.
4. Wipe the entire pipette with a soft cloth or lint-free tissue soaked with the cleaning solution.
5. Wipe it with distilled water.
6. Let the parts dry by evaporation or wipe them with a clean soft cloth or lint-free tissue.
7. Refit the tip ejector (refer to [Changing the Tip Ejector for Multichannel Models](#) on page 15).

Autoclaving

The upper part (body) and the piston assembly of the pipette are **not autoclavable**. **Only the following parts** may be autoclaved: tip ejector, tip holder, and connecting nut. The O-ring and seal are **not autoclavable**. They may be cleaned or replaced with the ones found in [SPARE PARTS](#) on page 18.

1. Clean the parts to be autoclaved, especially the tip holder.
2. Put the parts in an autoclaving sack.
3. Autoclave for 20 minutes at 121°C, 1 bar relative pressure.
4. Check that the parts are dry before reassembling the pipette.
5. Set the pipette aside to equilibrate to room temperature.
6. Reassemble the pipette (refer to Figure 12 on page 14).



Chemical Decontamination

You may choose to decontaminate your pipette chemically, in accordance with your own procedures. Whatever decontaminant you use, check with the supplier of the decontaminant to verify that it is compatible with stainless steel and the plastics used in the construction of the pipette: PA (Polyamide), PBT (Polybutylene Terephthalate), PC (Polycarbonate), PC/PBT (Polycarbonate/Polybutylene Terephthalate), POM (Polyoxymethylene), or PVDF (Polyvinylidene Fluoride), or PP (Polypropylene).

Chemical Decontamination for Single Channel Models

Upper Part (handle)

1. Wipe the upper part (handle) of the pipette with a soft cloth or lint-free tissue soaked with the chosen decontaminant.
2. Wipe the upper part of the pipette with a soft cloth or lint-free tissue soaked with distilled water or sterile water.

Lower Part (volumetric module)

Only the following components can be immersed in a decontaminant solution: connecting nut, tip ejector, and tip holder.

NOTE

The piston assembly and seals must be degreased with isopropanol or ethanol in a separate vessel before being immersed in decontamination solution.

1. Remove the tip ejector, the tip holder, and the connecting nut.
2. Immerse them in the decontamination solution.
3. Degrease the piston assembly and the seals. Then immerse them in another vessel of decontamination solution.
4. Rinse each component with distilled water.
5. Let the parts dry by evaporation. The tip ejector, tip holder, and connecting nut can be wiped dry with a soft cloth.
6. Lubricate the piston assembly and the seals.
7. Reassemble the piston assembly, the tip holder, and the tip ejector.

Chemical Decontamination for Multichannel Models

Only the following components be immersed in a decontamination solution: tip ejector, ejector locks, and ejector spacer.

1. Remove the tip ejector and the ejector spacer.
2. Immerse the tip ejector, ejector locks and ejector spacer in the decontamination solution or wipe them with a soft cloth or lint-free tissue soaked with the decontamination solution.
3. Rinse the components with distilled water.
4. Wipe the entire pipette with a soft cloth or lint-free tissue soaked with the decontamination solution.
5. Wipe the entire pipette with distilled water.
6. Let the parts dry by evaporation or wipe them with a clean soft cloth or lint-free tissue.
7. Refit the tip ejector (refer to [Changing the Tip Ejector for Multichannel Models](#), page 15).



Chapter 8 SPARE PARTS

Service Kit 1st level includes:

- 3 piston seals* or seal guides **C**
- 3 O-rings* **D**
- 1 tip holder **E**

Service Kit 2nd level includes:

- 1 push button **A**
- 1 connecting nut **B**
- Stainless steel tip ejector **F2**
- Plastic tip ejector **F1**
(also available separately as an accessory)

For the P2 and P10 models only:

- 5 dual-position adapter for stainless steel tip ejector **F3**
- 1 extension for plastic tip ejector **F4**

* For P5000, two piston seals and O-rings are provided in the Service Kit 1st level.

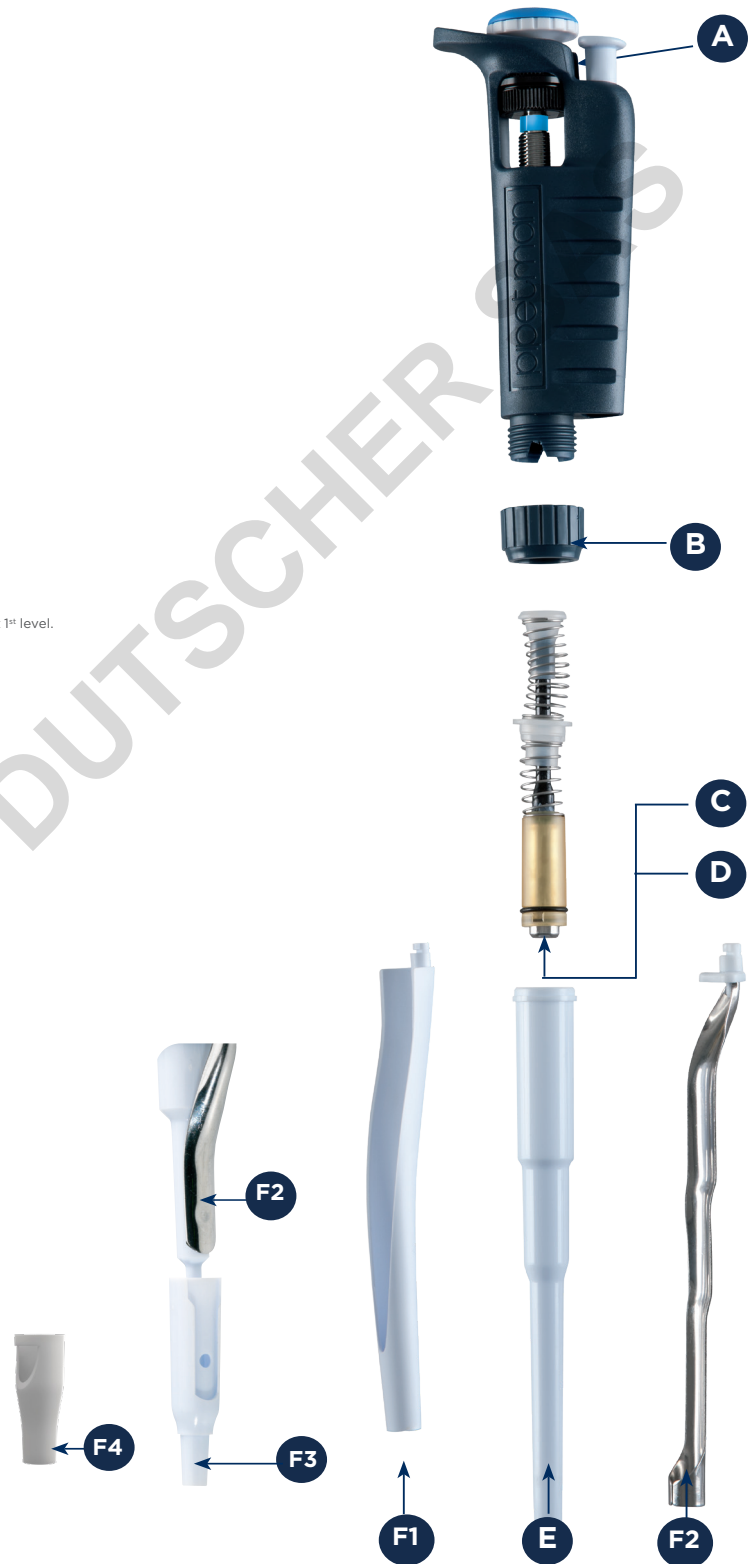

Figure 13
Spare parts identified



Single Channel Models

P2 (F144054M) AND P10 (F144055M)			
LABEL	DESCRIPTION	P/N FOR P2	P/N FOR P10
C+D+E	Service Kit 1st level	F144501	FA07001
A+B+F1 to F4	Service Kit 2nd level	F1619702	F1619712
C+D	Seal Guide + O-ring (5 sets)	F144861	FA07012
F3	Dual-Position Adapter (x5)	F144879	F144879
F4	Tip ejector extension	F2070903	F2070903

P20 (F144056M) AND P100 (F144057M)			
LABEL	DESCRIPTION	P/N FOR P20	P/N FOR P100
C+D+E	Service Kit 1st level	FA07002	FA07003
A+B+F1+F2	Service Kit 2nd level	F1619722	F1619732
C+D	Seal Guide + O-ring (5 sets)	FA07013	FA07014

P200 (F144058M) AND P1000 (F144059M)			
LABEL	DESCRIPTION	P/N FOR P200	P/N FOR P1000
C+D+E	Service Kit 1st level	FA07004	FA07005
A+B+F1+F2	Service Kit 2nd level	F1619742	F1619782
C+D	Seal Guide + O-ring (5 sets)	FA07015	FA07016

P5000 (F144066) AND P10ML (F144067)			
LABEL	DESCRIPTION	P/N FOR P5000	P/N FOR P10ML
C+D+E	Service Kit 1st level	FA07311	FA07312
C+D	Seal Guide + O-ring (2 sets)	FA07307	FA07308
E	Tip holder	FA07350	F161263

DESCRIPTION	PART NUMBER
Lubricant	5440011070

Multichannel Models

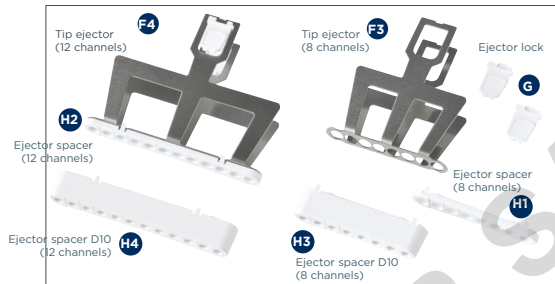

P8X10 (F144068) AND P12X10 (F144069)			
LABEL	DESCRIPTION	P/N FOR P8X10	P/N FOR P12X10
F3-F4	Tip ejector	F507005	F507006
G	Ejector lock	F507008	F507008
H1 - H2	Ejector spacer	F507001	F507003
H3 - H4	Ejector spacer D10	F807114	F807115

P8X20 (F144070) AND P12X20 (F144071)			
LABEL	DESCRIPTION	P/N FOR P8X20	P/N FOR P12X20
F3-F4	Tip ejector	F507005	F507006
G	Ejector lock	F507008	F507008
H1 - H2	Ejector spacer	F507001	F507003

P8X200 (F144072) AND P12X200 (F144073)			
LABEL	DESCRIPTION	P/N FOR P8X200	P/N FOR P12X200
F3-F4	Tip ejector	F507005	F507006
G	Ejector lock	F507008	F507008
H1 - H2	Ejector spacer	F507001	F507003

P8X300 (F144074) AND P12X300 (F144075)			
LABEL	DESCRIPTION	P/N FOR P8X300	P/N FOR P12X300
F3-F4	Tip ejector	F507005	F507006
G	Ejector lock	F507008	F507008
H1-H2	Ejector spacer	F507001	F507003



WARRANTY

Gilson warrants this pipette against defects in material under normal use and service for a period of **three years for both single channel and multichannel models** from the date of purchase.

This warranty shall not apply to pipettes which are subject to abnormal use and/or improper or inadequate maintenance (contrary to the recommendations given in the user's guide), including, but not limited to pipettes which have been subjected to physical damage, improper handling, or spillage or exposure to any corrosive environment. This warranty shall also be void in the event pipettes are altered or modified by any party other than Gilson or its designates. Gilson's sole liability under this warranty shall be limited to, at Gilson's sole option, repair or replacement of any defective components of pipettes or refund of the purchase price paid for such pipettes. **Routine cleaning, control, and recalibration are not covered under the warranty. The replacement of wearing parts such as seals, O-rings, broken pistons assembly, and broken tip holders are not covered under the warranty.**

NOTICE

Yearly routine maintenance is highly recommended to keep your pipette in good condition, ensuring a continued high level of performance.

THE FOREGOING WARRANTY IS EXCLUSIVE AND GILSON HEREBY DISCLAIMS ALL OTHER WARRANTIES, WHETHER EXPRESS OR IMPLIED, INCLUDING ANY WARRANTIES OF MERCHANTABILITY AND ANY WARRANTIES OF FITNESS FOR A PARTICULAR PURPOSE, UNDER NO CIRCUMSTANCES SHALL GILSON BE LIABLE FOR ANY CONSEQUENTIAL, PUNITIVE, INDIRECT OR INCIDENTAL DAMAGES ARISING OUT OF ANY BREACH OF ANY EXPRESS OR IMPLIED WARRANTY.



DOMINIQUE DUTSCHER SAS