

TECHNICAL DATASHEET

<p>Nom Produit <i>Product Name</i></p>	<p>Sachet Doypack® PET12/ALU8/PE100 <i>Doypack® bag PET12/ALU8/PE100</i></p>
---	---

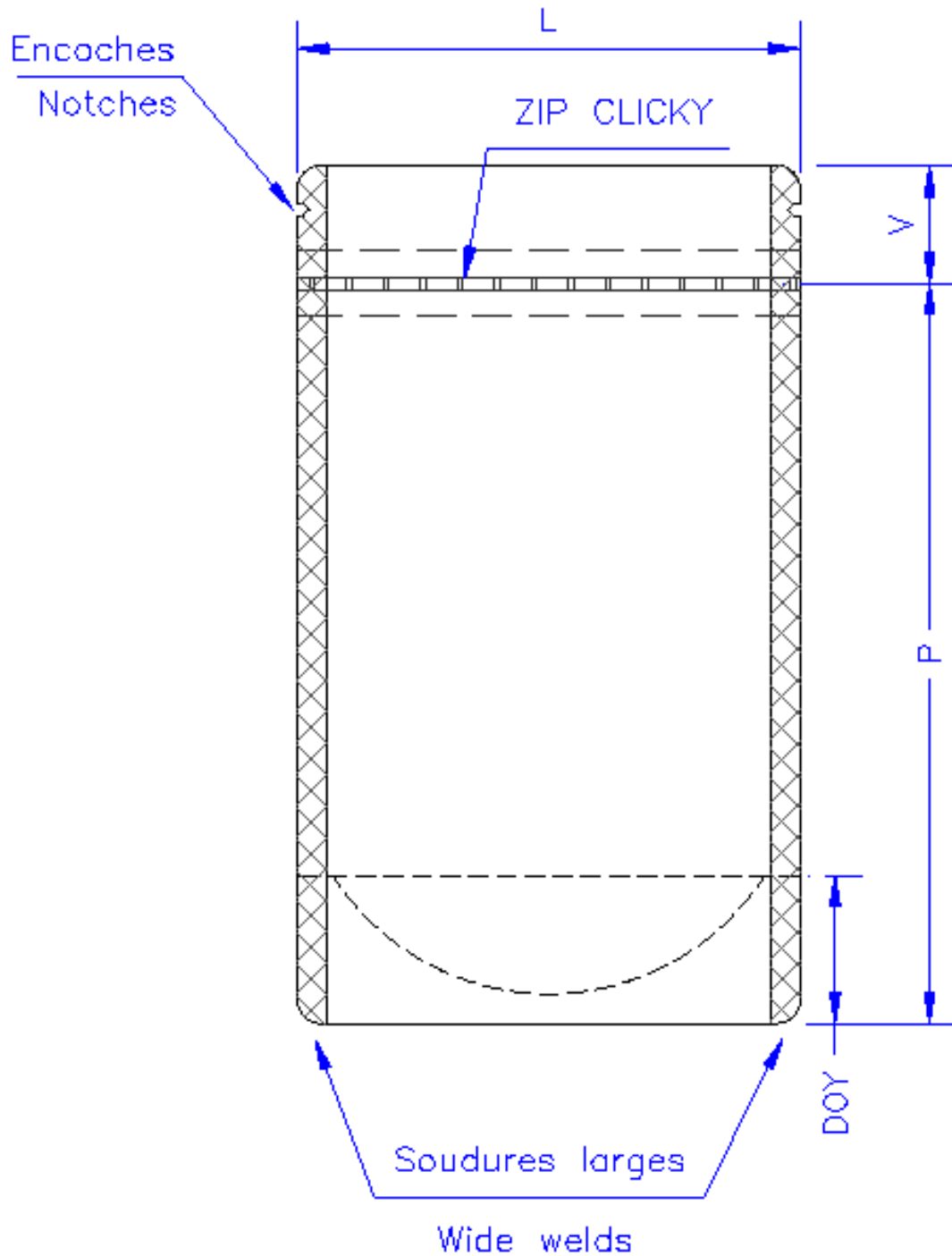

TECHNICAL DATASHEET

Nom Produit <i>Product Name</i>	Sachet Doypack® PET12/ALU8/PE100 <i>Doypack® bag PET12/ALU8/PE100</i>
---	---

DIMENSIONS	
<u>Voile (mm)</u>	V (± 5mm)
<u>Largeur (mm)</u>	L (± 5mm)
<u>Profondeur (mm)</u>	P (± 5mm)
<u>Soufflets latéraux (mm)</u>	SL (± 5mm)
<u>Patte (mm)</u>	PA (± 5mm)
<u>K-Seal (mm)</u>	K (± 5mm)

DIMENSIONS	
<u>Lip (mm)</u>	V (± 5mm)
<u>Width (mm)</u>	L (± 5mm)
<u>Depth (mm)</u>	P (± 5mm)
<u>Side gussets (mm)</u>	SL (± 5mm)
<u>Flap (mm)</u>	PA (± 5mm)
<u>K-Seal (mm)</u>	K (± 5mm)

DESCRIPTION	
<u>Matière</u>	PET / ALU / PE
<u>Epaisseur</u>	120 µm
<u>Fermeture</u>	Zip Clicky
<u>Couleur Fermeture</u>	Neutre
<u>Capacité</u>	2000 ml
<u>Aptitude au contact alimentaire</u>	OUI
<u>Recyclabilité</u>	Non recyclable

DESCRIPTION	
<u>Raw material</u>	PET / ALU / PE
<u>Thickness</u>	120 µm
<u>Closure</u>	Clicky zipper
<u>Closure Colour</u>	Neutral
<u>Capacity</u>	2000 ml
<u>Food contact compliance</u>	YES
<u>Recyclability</u>	Not recyclable

BARRIERES <i>Barriers</i>	UNITE <i>Unit</i>	VALEUR <i>Value</i>	NORME <i>standard</i>
<u>Oxygène</u> <i>Oxygen</i>	cm3/m2*24h 23C,0%RH1atm	0,99	ASTM D - 3985
<u>Vapeur d'eau</u> <i>Water vapour</i>	g/m2*24h 38C, 90%RH	0,75	ASTM F - 1249

ARTICLE <i>ARTICLE</i>	LxP <i>WxD</i> (mm)	VOILE <i>LIP</i> (mm)	SDF <i>BG</i> (mm)	POIDS NET <i>NET WEIGHT</i> (g)
ITM080206	210 X 270	40	2 X 55	22,7 (+/-10%)

TECHNICAL DATASHEET

Nom Produit <i>Product Name</i>	Sachet Doypack® PET12/ALU8/PE100 <i>Doypack® bag PET12/ALU8/PE100</i>
---	---

CONDITIONS D'UTILISATION	
❖	Température de stockage : 16 à 24°C
❖	Taux d'humidité relative : 35 à 55 %
❖	Les marchandises doivent être stockées dans un environnement, propre, sec et exempt d'infestation et non exposées directement à de fortes chaleurs, lumières et odeurs.
❖	Sous réserves des conditions de stockage mentionnées, nos produits sont garantis 12 mois à compter de la date de livraison.

CONDITIONS D'UTILISATION	
❖	Storage temperature : 16 à 24°C
❖	Relative humidity rate : 35 à 55 %
❖	The goods should be stored in a clean, dry environment and free from infestation, They should be protected against strong light, heat and odor.
❖	According to the mentioned storage conditions, our products are guaranteed for 12 months from the date of delivery.

VALIDATION
Date : 17/07/2023
 <p>FlexicoGroup® Ethical packaging solutions 1, Route de Méru, BP 70429-Ménerville 60544 Méru CEDEX Tél. : +33(0)3 44 49 49 49 Fax : +33(0)3 44 49 88 51 www.flexico.com SARL au capital de 3 000 000 € SIRET 440 296 689 000 19 TVA FR 48 440 296 689</p>
<i>Gilles de Maquillé</i>
<i>Directeur du Négoce</i> <i>Trading Director</i>